



5.0L Ford Holley SystemMax® Big Shot Kit

Kit Number: 02119NOS



OWNER'S MANUAL P/N 199R10329

CONGRATULATIONS on purchasing your NOS Nitrous Oxide Injection System. Your system is composed of the highest quality components available. It should provide many miles of trouble-free performance when used correctly. If you have any questions regarding the performance of your system, call NOS Technical Service at 1-866-GOHOLLEY.

NOTICE: Installation of Nitrous Oxide Systems Inc. products signifies that you have read this document and agreed to the terms stated within.

It is the purchaser's responsibility to follow all installation instruction guidelines and safety procedures supplied with the product as it is received by the purchaser to determine the compatibility of the product with the vehicle or the device the purchaser intends to install the product on.

Nitrous Oxide Systems Inc. assumes no responsibility for damages occurring from accident, misuse, abuse, improper installation, improper operation, lack of reasonable care, or all previously stated reasons resulting from incompatibility with other manufacturers' products.

Nitrous Oxide Systems Inc. assumes no responsibility or liability for damages incurred by the use of products manufactured or sold by Nitrous Oxide Systems Inc. on vehicles used for competition or racing.

Nitrous Oxide Systems Inc. neither recommends nor condones the use of products manufactured or sold by Nitrous Oxide Systems Inc. on vehicles, which may be driven on public roads or highways, and assumes no responsibility for damages incurred by such use.

NOS nitrous oxide is legal for use in most states when used in accordance with state and local traffic laws. NOS does not recommend or condone the use of its products in illegal racing activities.

NOTICE: The NOS 5.0 Ford Big Shot System Kit is not intended for use on hatchback type vehicles without the use of NOS part numbers 16160NOS (External Aluminum Blow-Down Tube) and 16169NOS (Racer Safety Pressure Relief Cap).

HAZARDS DEFINED

This manual presents step-by-step instructions that describe the process of installing your NOS Nitrous Oxide Injection System. These procedures provide a framework for installation and operation of this kit. Parts are referenced by name and number to avoid confusion. Within the instructions, you are advised of potential hazards, pitfalls, and problems to avoid. The following examples explain the various hazard levels:

WARNING! Failure to comply with instructions may result in injury or death.

CAUTION! Failure to comply with instructions may result in damage to equipment.

NOTE: This information is important, needs to be emphasized, and is set apart from the rest of the text.

HINT: These special instructions provide a handy work tip.

NITROUS OXIDE INJECTION SYSTEM SAFETY TIPS

WARNINGS

Do not attempt to start the engine if the nitrous has been injected while the engine was not running. Disconnect the coil wire and turn the engine over with the throttle wide open for several revolutions before attempting to start. Failure to do so can result in extreme engine damage.

Never permit oil, grease, or any other readily combustible substances to come in contact with cylinders, valves, solenoids, hoses, and fittings. Oil and certain gases (such as oxygen and nitrous oxide) may combine to produce a flammable condition.

Never interchange nitrous and fuel solenoids. Failure to follow these simple instructions can result in extreme engine damage and/or personal injury.

Never drop or violently strike the bottle. Doing so may result in an explosive bottle failure.

Never change the pressure settings of the safety relief valve on the nitrous bottle valve. Increasing the safety relief valve pressure settings may create an explosive bottle hazard.

Please note that the NOS bottle label has changed to a two-part assembly. The first label is already located on the bottle. Upon filling your bottle with nitrous oxide, apply the (second) material information label in the area indicated in the picture to the right.

NOTE: The material information decal is located in the same plastic bag as the bottle.

WARNING! Once the nitrous bottle has been filled, it must be shipped according to the applicable transportation and shipping regulations!

Do not deface or remove any markings, which are used for content identification.

Nitrous bottle valves should always be closed when the system is not being used.

Notify the supplier of any condition that may have permitted any foreign matter to enter the valve or bottle.

Keep the valves closed on all empty bottles to prevent accidental contamination.

After storage, open the nitrous bottle valve for an instant to clear the opening of any possible dust or dirt.

It is important that all threads on the valves and solenoids are properly mated. Never force connections that do not fit properly.

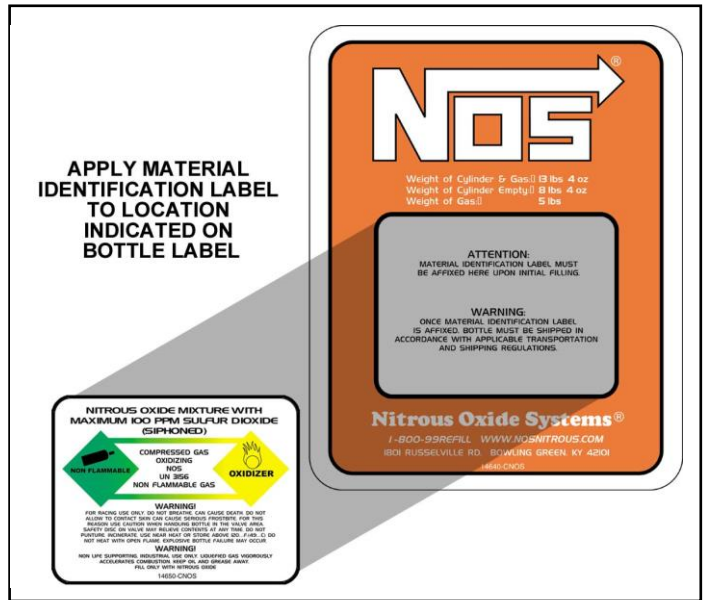

Identify the gas content by the NOS label on the bottle before using. If the bottle is not identified to show the gas contained, return the bottle to the supplier.

Do not deface or remove any markings, which are on the nitrous bottle.

Nitrous bottle valves should always be closed when the system is not being used.

Notify the supplier of any condition, which might have permitted any foreign matter to enter the valve or bottle.

Keep the valves closed on all empty bottles to prevent accidental contamination.

After storage, open the nitrous bottle valve for an instant to clear the opening of any possible dust or dirt.

It is important that all threads on the valves and solenoids are properly mated. Never force connections that do not fit properly.

TABLE OF CONTENTS

WHAT IS NITROUS OXIDE?	5
Do's and Don'ts of Nitrous Oxide	5
Chapter 1 Introduction to your NOS Nitrous Oxide Kit	6
1.1 General Information	6
1.2 System Requirements	6
1.3 Kit Components	7
Chapter 2 Kit Installation	8
2.1 Bottle Mounting Instructions	8
2.1.1 Street Vehicles	8
2.1.2 Racing Vehicles	9
2.2 Bottle Orientation	9
2.3 Bottle Installation	9
2.4 Injector Plate Installation	10
2.5 Nitrous Solenoid	11
2.6 Fuel Solenoid	11
2.7 Nitrous Feed Line Mounting	12
2.8 Fuel Line Connection	12
Chapter 3 Preparing for Operation	14
Chapter 4 Tuning Suggestions	15
4.1 Tuning Suggestions	15
4.1.1 Determining Optimum System Performance	15
4.2 Advanced Tuning for Maximum Power	16
4.2.1 Determining Optimum Ignition Timing	16
Appendix A Troubleshooting Guide	16
Nitrous Oxide Accessories	17

WHAT IS NITROUS OXIDE?

NITROUS OXIDE...

...Is a cryogenic gas composed of nitrogen and oxygen molecules

...Is 36% oxygen by weight

...Is non-flammable by itself

...Is stored as a compressed liquid

...Exists in two grades—U.S.P. and Nitrous Plus:

- U.S.P. is medical grade nitrous oxide; its common use is dental and veterinary anesthesia. It is also commonly used as a propellant in canned whipped cream. U.S.P. is not available to the public.
- Nitrous Plus differs from U.S.P. in that it contains trace amounts of sulphur dioxide added to prevent substance abuse. Nitrous Plus is intended for automotive applications and is available for sale to the public

In automotive applications, Nitrous Plus and fuel are injected into the engine's intake manifold, which produces the following results:

- Lowers engine intake air temperature, producing a dense inlet charge.
- Increases the oxygen content of the inlet charge (air is only 22 percent oxygen by weight).
- Increases the rate at which combustion occurs in the engine's cylinders.

Do's and Don'ts of Nitrous Oxide

Do's

- Read **all** instructions before attempting to install your NOS nitrous system.
- Make sure your fuel delivery system is adequate for the nitrous jetting you have chosen. Inadequate fuel pressure or flow **will** result in engine damage.
- Use the recommended gauge of wire when installing electrical system components.
- Use high-quality connections at all electrical joints.
- Use PTFE-based **paste** on pipe style fittings.
- Make sure your engine and related components (ignition, carburetor, and driveline) are in proper working condition.
- If nitrous is accidentally injected into the engine when it is not running, remove the engine coil wire, open the throttle, and crank the engine 10 to 15 seconds before starting. Failure to do so can result in an explosive engine failure.**
- Use your NOS nitrous system only at wide-open throttle and at engine speeds above 3000 RPM.**
- Install a proper engine to chassis ground. Failure to do so may result in an explosive failure of the main nitrous supply line.**
- Use a high-quality fuel, as suggested in Chapter 4, Tuning Suggestions.

Don'ts

- Engage your nitrous system with the engine off. **Severe** engine damage can occur.
- Modify NOS nitrous systems (if you need a non-stock item, call NOS Technical Service for assistance)
- Overtighten AN style fittings.
- Use PTFE Tape on any pipe threads.
- Use sealant of any kind on AN style fittings.
- Inhale nitrous oxide. Death due to suffocation can occur.**
- Allow nitrous oxide to come in contact with skin. Severe frostbite can occur.**
- Use octane boosters that contain methanol. Fuel solenoid failure may occur, producing severe engine damage.

Chapter 1 Introduction to your NOS Nitrous Oxide Kit

1.1 General Information

Kit Number 02119NOS is intended for use on modified 1986-1995 5.0 Ford engines equipped with Holley SystemMax intake manifolds. Horsepower and torque increases will vary with engine displacement and modification. Approximate power increases can be estimated based upon the massflow of nitrous oxide into the engine.

The following jet combinations are supplied with this kit to allow you to vary your engine's power output. On a typical mildly modified 5.0 engine, you can expect the following approximate power gains for each of the nine jetting combinations:

Table 1 Jetting and Power Levels

Jetting N ₂ O/Fuel	Power Levels
43/31	100 HP
52/33	125 HP
59/37	150 HP*
65/40	175 HP
71/42	200 HP*
76/45	225 HP
81/47	250 HP*
86/51	275 HP*
91/52	300 HP

* HP Jetting included in kit

NOTE: 200HP+ jetting levels are not recommended for use in engines that feature the stock Ford rotating assembly and cylinder block. Refer to Section 1.2 "System Requirements" for suggestions.

Typically, the standard #10 (10 lb.) bottle of nitrous will supply just under a minute of operation at wide-open throttle. A full #10 bottle will weigh 25 lbs. For best performance, the bottle should be refilled when it weighs 17 to 18 lbs.

1.2 System Requirements

When used correctly, NOS nitrous oxide injection elevates cylinder pressures and temperatures while increasing the combustion rate. These characteristics make the engine more sensitive to detonation. **To ensure proper performance and engine life, the following guidelines should be followed:**

Adequate Fuel Pressure and Delivery

Your fuel delivery system must be capable of supplying at least 0.10 gallons (.60 lbs.) of *gasoline* per hour per horsepower at 40-45 psi. NOS, as well as numerous other manufacturers, sell auxiliary high performance high-pressure fuel pumps.

Forged Pistons

Cast pistons are very prone to failure at elevated cylinder temperatures and pressures.

Connecting Rods

Standard connecting rods tend to buckle under the high compressive loads generated with large doses of N₂O (200+ HP).

Crankshaft

Stock-type cast crankshafts are breakage prone when subjected to severe duty. A quality forging is recommended.

Cylinder Block

When adding over 200 HP with nitrous oxide injection, a stronger cylinder block, such as a SVO unit is suggested. Stock late model 5.0 cylinder blocks tend to crack in the main web area when subjected to severe duty.

Ignition System

The stock Ford ignition system is prone to misfiring when used at high-RPM in conjunction with nitrous oxide. A high output ignition system is recommended.

1.3 Kit Components

Before beginning the installation of your NOS kit, compare the components in your kit with those shown in Figure 1 & 2, and listed in Tables 1 & 2. If any components are missing, please contact NOS Technical Support at 1-866-464-6553.

Table 2 5.0 Ford Systemax Big Shot Nitrous Oxide Injection Kit Parts List—Kit #02119NOS

Item	Description	Quantity	NOS P/N
(1)	Bottle Valve Adapter	1	16230NOS
(2)	Bottle Valve Washer	1	16210NOS
(3)	Bottle Mounting Bracket Set	1	14125NOS
(4)	Bottle 10 lb.	1	14745NOS
(5)	5/16" x 2" Injector Plate Stud	1	37R512
(6)	5/16" Fine Thread Nut	1	17997-SNOS
(7)	5/16" Washers	6	17995-SNOS
(8)	5/16" x 7" Allen Bolt	1	5R2184
(9)	Injector Plate Gasket	2	8R2159
(10)	Injector Plate	1	40R809A
(11)	Nitrous Solenoid	1	18045NOS
(12)	Solenoid Bracket	2	16500NOS
(13)	1/4 NPT x 6AN Nitrous Filter	1	15564NOS
(14)	5/16" x 2" Allen Bolt	4	5R2185
(15)	1/8NPT x 4AN fitting (Blue)	1	17960NOS
(16)	N ₂ O Supply Hose 18" (Blue)	1	15345NOS
(17)	Fuel Supply Hose 12" (Red)	1	15341NOS
(18)	SS Precision Flare Jets (.037,.042,.047,.051,.059,.071,.081,.086)	8 (1 ea.)	13760-xx-SNOS*
(19)	Fuel Solenoid	1	18050NOS
(20)	1/8 NPT x 4AN Fitting (Red)	1	17961NOS
(21)	30A Heavy Duty Relay	1	15618NOS
(22)	Red Fuel Hose 4AN (18")	1	15221NOS
(23)	1/16 NPT x 4AN fitting	1	17945NOS
(24)	Main N ₂ O Feed Line Blue 6AN (14 ft.)	1	15475NOS
(25)	Microswitch Bracket	1	15645-VSNOS
(26)	Solenoid Mounting Screws	2	16502-SNOS
(27)	Solenoid Mounting Screws	4	16501-SNOS
(28)	5/16" x 7 1/2" Allen Bolt	1	5R2186
(29)	Relay Wiring Harness	1	15604-SNOS
(30)	6AN Black Cap Plug	1	A1002-SNOS
(31)	14 Gauge Blue Wire	1	15751-VSNOS
(32)	16 Gauge Red Wire	1	15755-VSNOS
(33)	14 Gauge Green Wire	1	15778-VSNOS
(34)	4AN Red Fuel Filter	1	15571NOS
(35)	Basic Wire Pack	1	15612-VSNOS
	<i>Rocker Switch</i>	1	15602NOS
	<i>15 amp Fuse</i>	1	208R2
	<i>Microswitch</i>	1	15640NOS
	<i>Microswitch Mounting Screws</i>	2	15647-SNOS
	<i>Microswitch Mounting Nuts</i>	2	15648-SNOS
	<i>1/4" Ring Terminals</i>	3	15882-SNOS
	<i>Blue Female Spade Connectors</i>	7	15885B-SNOS
	<i>Blue Male Spade Connector</i>	1	15886B-SNOS
	<i>Scotchlock</i>	1	15891-SNOS
(36)	Relay Supplement Wire Pack	1	15611-SNOS
	<i># 6 Open Spade Terminals</i>	2	15880-SNOS
	<i>#10 Ring Terminals</i>	2	15881-SNOS
	<i>1/4" Ring Terminal</i>	1	15882-SNOS
	<i>Blue Male Spade Connector</i>	1	15886B-SNOS
	<i>Green Male Spade Connectors</i>	2	15888G-SNOS
	<i>Ring Terminal</i>	1	204R241-9

* Example: 13760-24-SNOS is .024 size jets

Figure 1 Kit Number 02119NOS—Component Identification

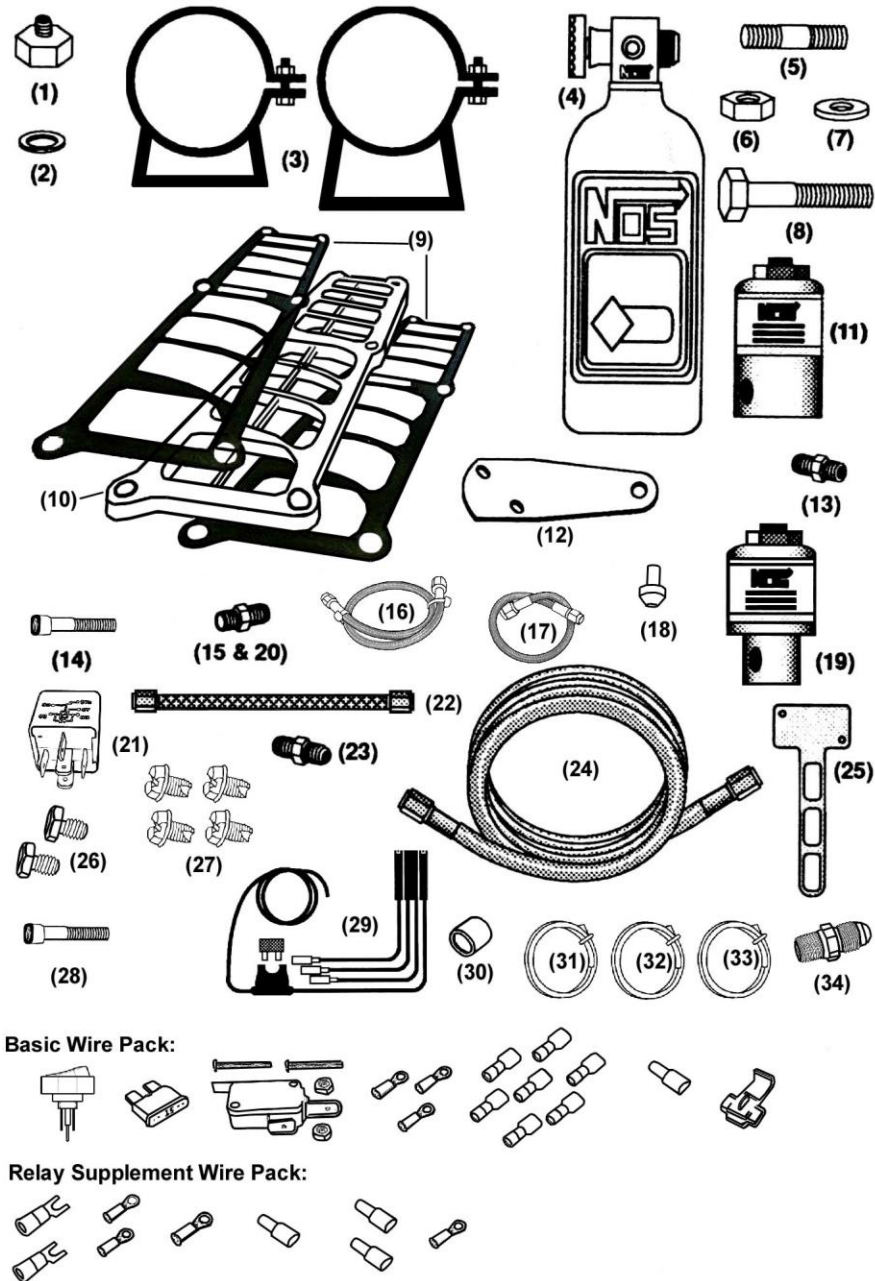

Chapter 2 Kit Installation

2.1 Bottle Mounting Instructions

NOTE: Disconnect the battery ground before beginning installation.

2.1.1 Street Vehicles

Accurate calibration of your NOS nitrous system depends on the bottle remaining at a stable temperature. Mount the bottle away from heat sources, such as the engine compartment or exhaust system, and away from windows, where the bottle is exposed to direct sunlight.

NOS recommends that the bottle be environmentally separated from the driver's compartment. Because hatchback-type vehicles generally do not have a firewall between the trunk area and the driver's compartment, the safety pressure relief cap should be replaced with P/N 16169NOS, and P/N 16160NOS should be added. P/N 16160NOS is an aluminum blow-down tube (an -8 neoprene lined braided hose can be substituted). The blow-down tube should be routed to the exterior of the vehicle (preferably under the vehicle). This procedure will prevent filling the driver's compartment with a cloud of nitrous oxide if the safety pressure relief cap should happen to rupture for any reason.

2.1.2 Racing Vehicles

Before mounting a nitrous bottle in a racing vehicle intended for use in sanctioned events, check with the sanctioning association for any rules regarding this subject. Most associations require the bottle to be mounted within the confines of the safety roll cage with the safety pressure relief cap vented away from the driver's compartment.

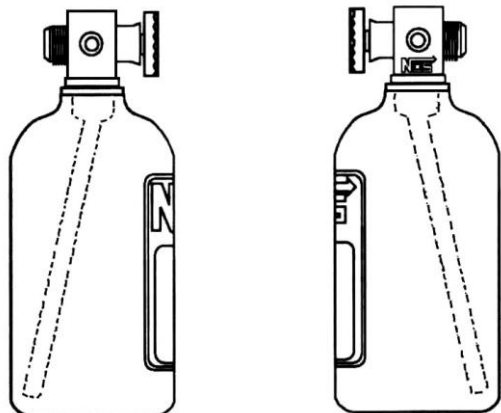

Figure 2 Nitrous Bottle Siphon Tube Orientation

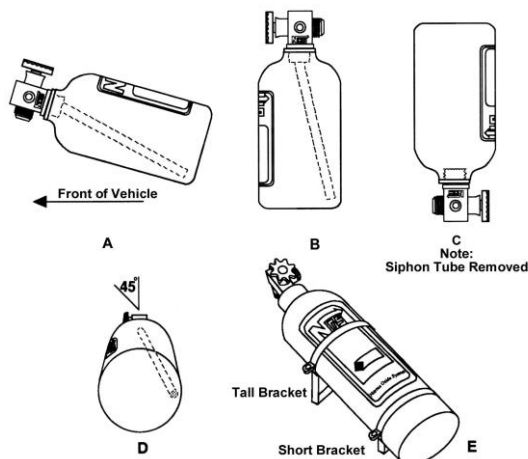

Figure 3 Nitrous Bottle Mounting Orientations

2.2 Bottle Orientation

Bottle placement is critical to the performance of your NOS nitrous system. It is important to understand how the bottle valve and siphon tube are assembled to properly orient the bottle in your vehicle and ensure that it picks up liquid nitrous while undergoing acceleration. All NOS nitrous bottles are assembled so that the bottom of the siphon tube is at the bottom of the bottle and opposite the bottle label (Figure 2).

Whenever the bottle is mounted in a lay-down position, the valve handle must be towards the front of the vehicle with the label facing up (Figure 3A).

If the bottle is mounted vertically, the valve handle and label must face toward the front of the vehicle (Figure 3B). This orientation will position the siphon tube at the back of the bottle where the liquid N_2O will be during acceleration.

WARNING! DO NOT attempt to remove the siphon tube without completely emptying the bottle of all nitrous and pressure.

A bottle mounted upside-down must have the siphon tube removed before use (Figure 3C). Non-siphon bottles can be specially ordered from NOS.

If the bottle must be mounted parallel to the axles of the vehicle (sideways), the valve handle and label must be angled at approximately 45° toward the front of the vehicle (Figure 3D). This orientation will position the siphon tube toward the rear of the bottle.

NOTE: When using a bottle with a siphon tube, the tall bracket should be at the valve end of the bottle and the short bracket at the bottom (Figure 3E).

The most efficient mounting is the lay-down position (Figure 3A) with the valve handle toward the front of the vehicle. This position allows the greatest amount of liquid to be used before the siphon tube begins to pick up gaseous nitrous oxide.

2.3 Bottle Installation

After you have determined the location and orientation of the nitrous bottle, use the following procedure to install the bottle:

NOTE: Numbers in parentheses () refer to the parts list /assembly drawing number for the component. Figure 5 shows the installation assembly for kit number 02119NOS.

1. Install the bottle nut adapter (1) and washer (2) on the nitrous bottle (4), and tighten securely.
2. Loosely install the bottle mounting brackets (3) on the nitrous bottle.
3. Locate the bottle assembly in the desired mounting area, ensuring that the location will provide easy access to the bottle valve, hose connection, and bracket clamp bolts to facilitate bottle changing.
4. Use the assembled bottle/bracket unit as a pattern to mark for hole drilling. Drill four $5/16"$ holes for the bottle bracket bolts.

5. Mark the location for the Main N₂O Feed Line (24) to pass through the floorpan of the vehicle to the underside. Drill a 3/4" hole at the marked location.
6. Mount the brackets securely to the surface (recommended minimum of 5/16" bolts or No. 12 sheet metal screws).
7. Tighten the bracket clamps on the bottle.

Figure 4 Kit Number 02119NOS Assembly Drawing

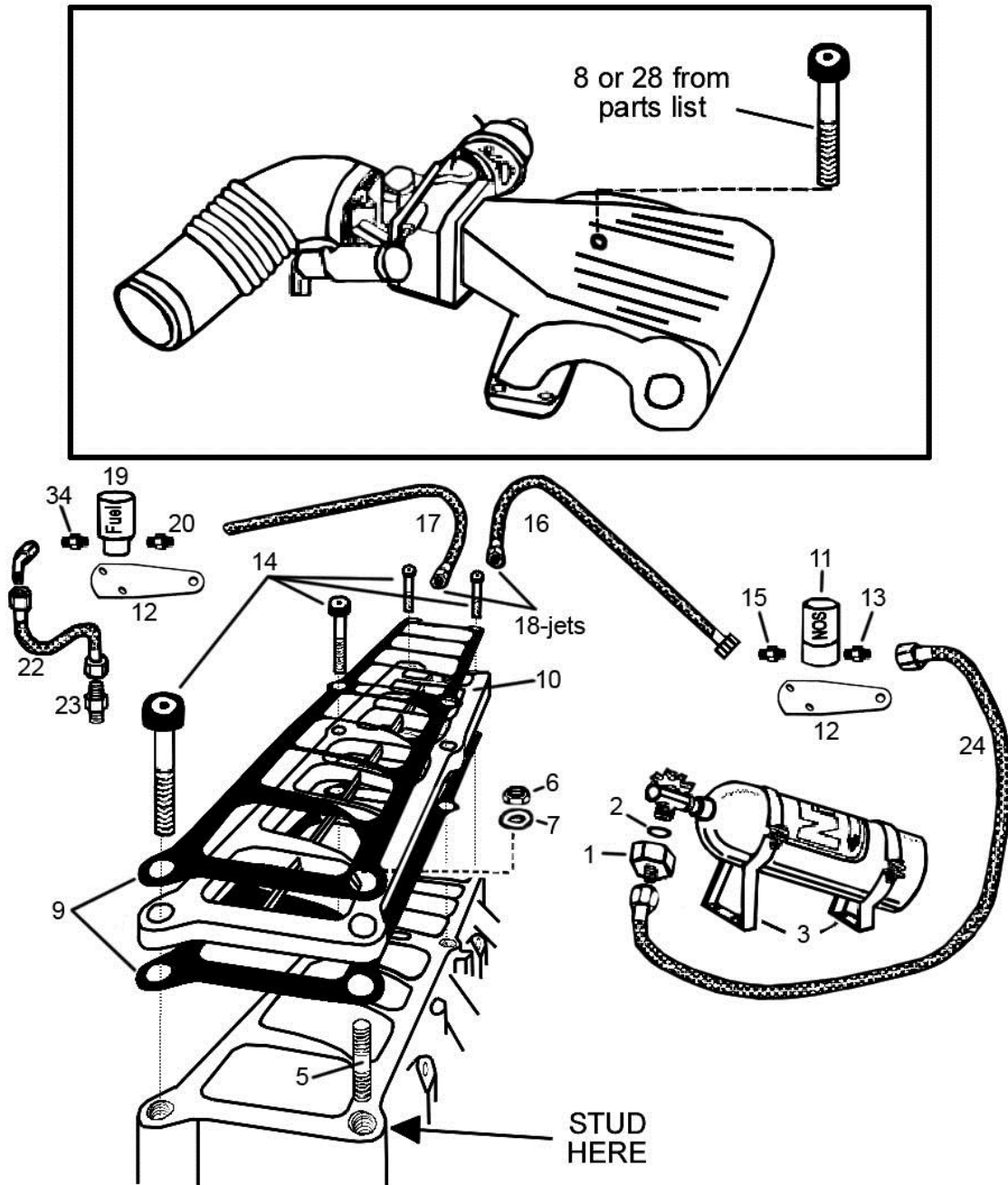

2.4 Injector Plate Installation

Use the following procedure to install the injector plate:

1. Disconnect the air inlet hose from the throttle body.
2. Disconnect the throttle linkage from the throttle body.
3. Disconnect the wiring from the Throttle Position Sensor, Idle Air Control Motor, and the EGR Valve.

4. Remove the 3 vacuum hoses from the rear of the intake plenum.
5. Remove the intake plenum hold-down nuts and bolts.
6. Remove the intake plenum and throttle body assembly.
7. Install the new injector plate stud (5) into the lower intake manifold. Refer to Figure 5 for stud location.
8. Install the new intake manifold gasket (9) and injector plate (10). The plate can only oriented one way when properly assembled and installed (note "THIS SIDE UP" etched in plate surface).
9. Install the new manifold gasket and upper intake manifold. Use 5/16" nuts (6), washers (7), and bolts (8 or 28 and 14) to secure the upper intake. The (8) bolt should be used with the new style intake. The (28) bolt (tapered head) should be used with the old style intake.
10. Reconnect the 3 vacuum hoses to the intake manifold plenum.
11. Connect the wiring to the TPS, Idle Air Control Motor and the EGR Valve.
12. Reconnect the throttle linkage.
13. Reconnect the air inlet hose from the throttle body.

2.5 Nitrous Solenoid

NOTE: Remember to use PTFE **paste** on all pipe threads.

CAUTION! Do not overtighten the vise in the following procedure, or the solenoid will be damaged.

1. Clamp the nitrous solenoid (11) in a bench vise.
2. Install the nitrous filter fitting (13) in the inlet port of the nitrous solenoid. Tighten Securely.
3. Remove from vise. Attach the nitrous solenoid to the mounting bracket (12) using screws (27).
4. Locate a suitable mounting location for the nitrous solenoid, knowing the length (18 inches) of the nitrous supply line must reach the plate.
5. With the solenoid securely mounted to the vehicle, thread the nitrous supply line (16) onto the nitrous solenoid fittings, and onto the threaded flare adapter of the nitrous plate (marked N).
6. Tighten the 4AN nitrous supply fittings hand tight, plus ½ turn.

2.6 Fuel Solenoid

NOTE: Remember to use PTFE **paste** on all pipe threads.

CAUTION: Do not overtighten the vise in the following procedure, or the solenoid will be damaged.

1. Place the fuel solenoid (19) in a bench vise.
2. Install the 1/8 NPT x 4AN red fitting (20) in the inlet port of the fuel solenoid.
3. Remove from vise. Attach the mounting bracket (12) to the fuel solenoid using screws (27).
4. Locate a mounting position which is as close to the fuel rail test port as possible, knowing the line length (18 inches) of the fuel supply line must reach the plate.
5. With the solenoid position chosen, securely mount the fuel solenoid and bracket to the vehicle. Here is one possible mounting configuration.
6. Once the solenoid is mounted, tighten the 4an fuel supply fittings by hand, plus ½ turn.

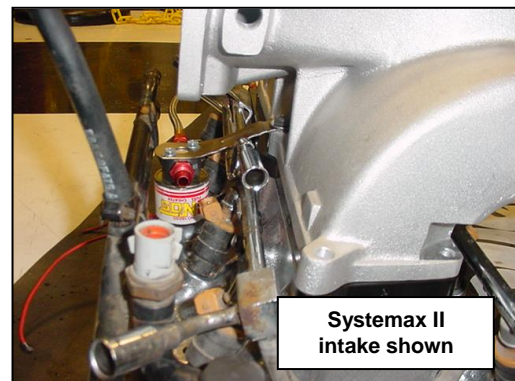

2.7 Nitrous Feed Line Mounting

HINT: Most late model Fords have access plugs in the trunk floor that are convenient for line routing. Following the fuel lines along the underbody, and entering the engine bay through the front fender well between the plastic inner fender panel and the body usually works well.

1. Determine the route for your nitrous feed line to follow. Ensure the path is clear of exhaust system, suspension, steering, wheels, electrical lines and components, and tires.
2. Feed the nitrous supply line (24) along the proposed route.
3. If it is necessary to support the nitrous supply line under the vehicle, use 1/2" Tinnerman clamps or nylon tie-wraps to support the line securely.
4. Attach the nitrous supply line to the nitrous bottle valve adapter (1).
5. Attach the nitrous supply line to the nitrous solenoid (11) inlet port.

2.8 Fuel Line Connection

IMPORTANT: When using stock fuel rails for supplying the NOS fuel solenoid, power gains from your NOS kit are limited to 150 HP due to the restrictive nature of the fuel rail test port orifice. Attempting to exceed this limit may result in an explosive engine failure.

NOTE: This nitrous system was designed to work with the "pre-94/95 model year" rounded fuel rails. 94/95 model vehicles must retro-fit these rails for a proper fit.

1. Locate the fuel rail test port fitting. Remove the protective cap. Cover the fitting with a rag (if the fuel rail is pressurized).
2. Bleed the fuel pressure from the fuel rail by pushing in the plunger in the fuel rail test port fitting.
3. Remove the fuel rail test port fitting from the fuel rail. Use caution not to get debris into the passage.
4. Install the 1/16 NPT x 4AN fitting in the fuel rail test port opening (using PTFE paste).
5. Using the 4AN x 18" hose, connect the fuel solenoid to the test port adapter.
6. Tighten the 4AN hose to the test port adapter. Hand tighten, plus 1/2 turn.

2.9 Electrical System Installation

WARNING! Death or injury may occur from working on a charged electrical system.

1. Disconnect the car battery at the ground cable (if not already done).
2. Refer to the wiring schematic (Figure 5) for electrical system installation.

WARNING! Binding or dragging of the throttle linkage will create a potentially dangerous stuck-throttle condition. Ensure that the microswitch does not interfere with normal throttle linkage operation.

3. Install the throttle microswitch as follows:

HINT: The microswitch may be mounted to the bracket in a variety of positions and on either side of the bracket. The bracket may be bent to suit the application.

- A. Mount the throttle microswitch on the throttle body so that the throttle linkage movement triggers the microswitch.
 - B. Adjust the microswitch to trigger at wide-open throttle by adjusting the microswitch's position to ensure the actuation arm of the microswitch "clicks" at the same point your throttle linkage reaches wide-open throttle against the throttle stop (Position 7A).
 - C. Ensure that the accelerator pedal activates the microswitch: Slowly press the throttle to the floor while you listen for the "click" of the microswitch (Position 7B).
4. Install the NOS arming switch in the vehicle interior, within easy reach of the driver. This switch is to be used to activate the nitrous system once safe engine RPM levels are reached.

CAUTION! Never activate your nitrous system below 3000 engine RPM. The installation of a Throttle RPM-Activated Switch is highly recommended to reduce the risk of engine damage while using this kit. Call NOS Technical Support for the right RPM-Activated switch for your particular vehicle.

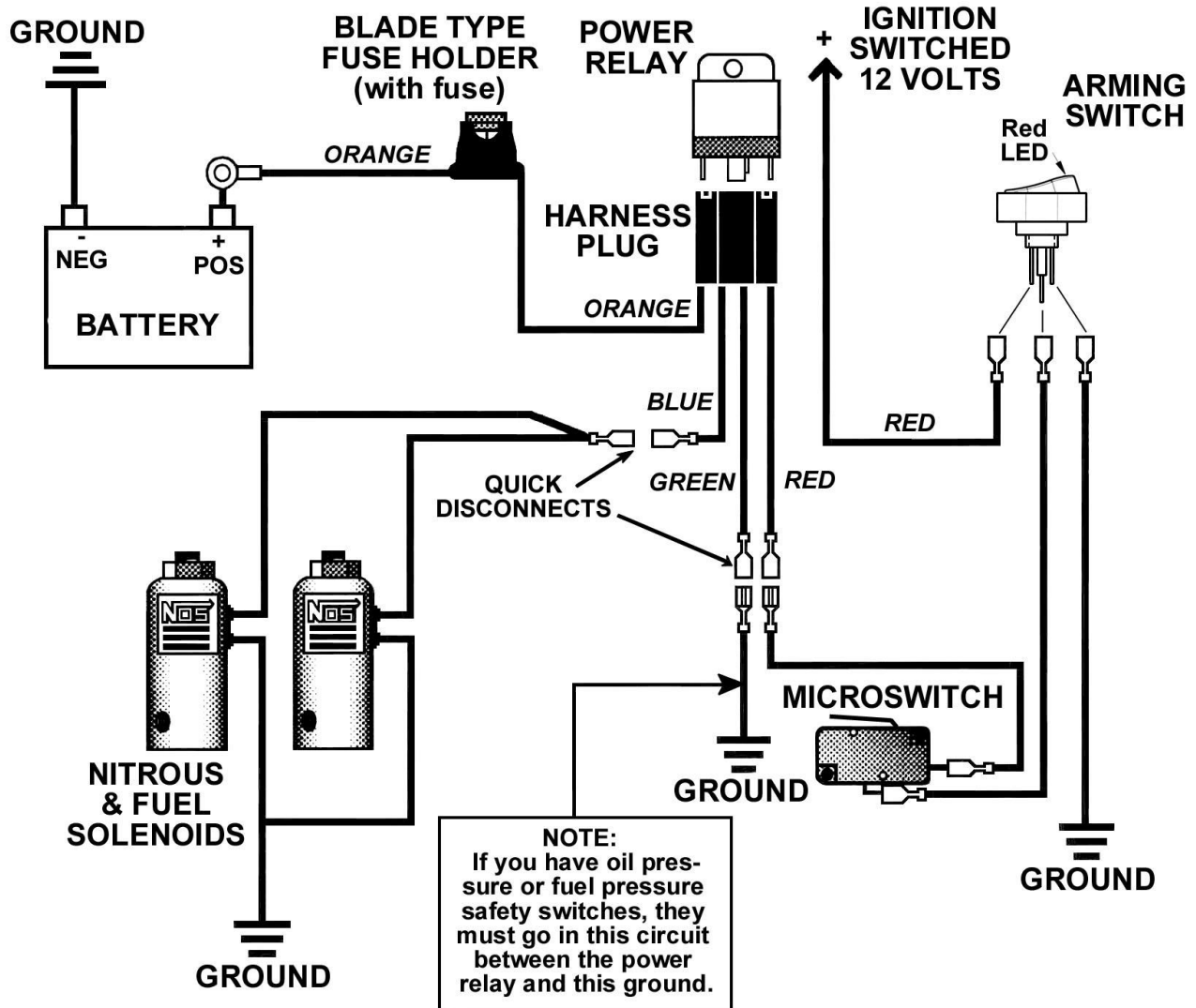

Figure 5 Wiring Schematic for Kit Numbers 02119NOS

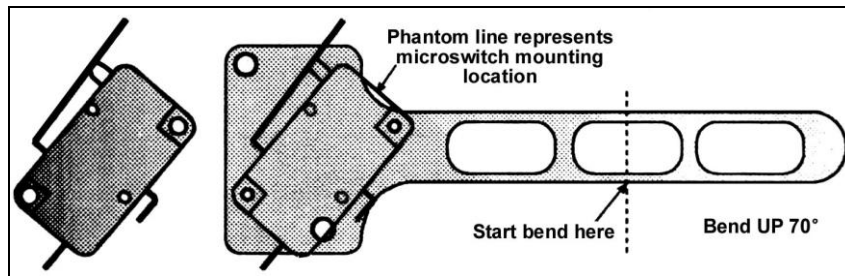
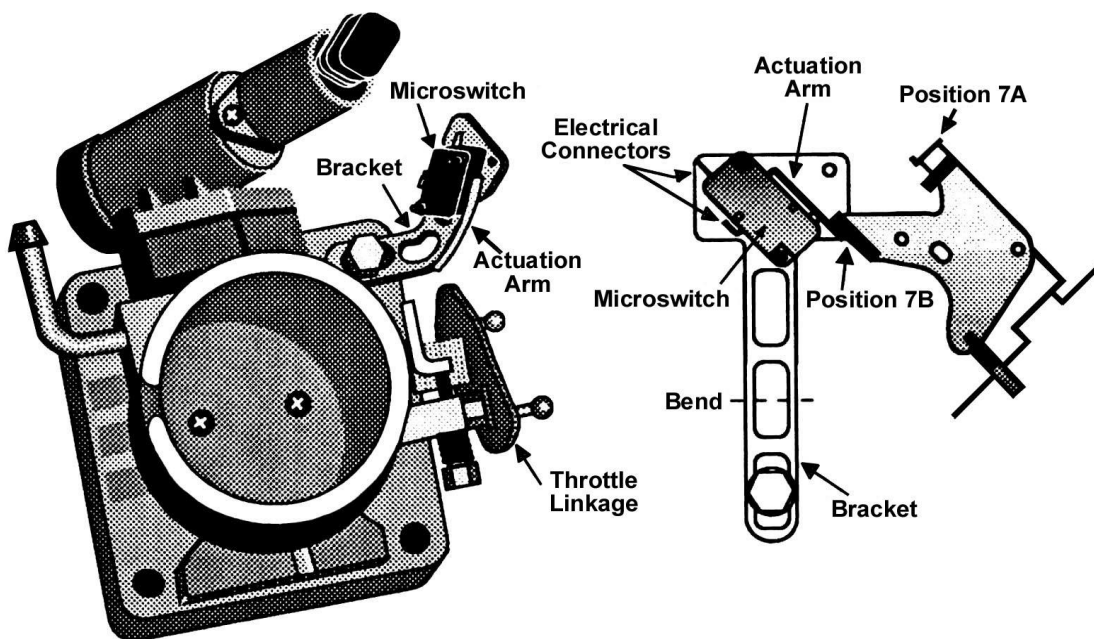

Figure 6 Microswitch Template—Suggested Mounting Configuration

5. Install the wiring relay and relay harness in the engine compartment near the battery. The relay's orange wire should reach the battery (+) terminal.
6. Connect the orange relay wire to the battery (+) terminal. Install a 15 AMP fuse into the fuse socket.
7. Connect one wire from each solenoid together. Join the solenoid wires to the blue relay wire.
8. Join the remaining solenoid wires together. Connect to a good chassis ground.
9. Connect the green relay wire to a good chassis ground.

10. Connect red relay wire to either terminal on the microswitch.
 11. Connect the terminal away from the LED on the arming switch to an ignition switched +12V source, using the fused red wire provided.
- NOTE:** When selecting an ignition switched +12V source, ensure that your source is capable of handling the amperage of the fuse provided by NOS.
12. Connect the center terminal of the arming switch to one post of the WOT microswitch (either post will do), with the blue wire provided.
 13. Connect the remaining terminal of the arming switch to the ground. (You may elect to skip this step. If you do so, the light in the arming switch will not illuminate when the system is armed).
 14. Connect the open post of the WOT microswitch to one wire from each solenoid (either wire will do, the solenoids are not polarized), using the blue wire provided.
 15. Connect the open wire from each solenoid to the ground.
 16. Reconnect the battery.
 17. Turn the arming switch on.
 18. Push the throttle wide open while the engine is off. Each solenoid should make a clicking noise if it is cycling correctly. If no noise is heard, check all the wiring connections and the wiring schematic in Figure 6.

Figure 7 Microswitch Installation



Chapter 3 Preparing for Operation

1. Turn on the vehicle's ignition. Check all systems for leaks. Start the engine. Open the nitrous bottle valve.

NOTE: There should be no change in the engine idle speed or exhaust tone. If either change is noted, refer to Appendix A, Troubleshooting Guide.

2. Inspect the nitrous lines and fittings for leaks.
3. ENJOY!

Chapter 4 Tuning Suggestions

4.1 Tuning Suggestions

Your NOS 5.0 Ford Big Shot System Kit comes with four sets of nitrous and fuel jets. For maximum performance, the following tuning tips are suggested. Table 4 lists some suggested tuning combinations, based upon 950 psi N₂O bottle pressure.

NOTE: Your combinations may vary. These guidelines are suggested as a safe starting point in tuning.

Table 3 Suggested Tuning Combinations for NOS 5.0L SystemMax Ford Big Shot Systems

Jetting N ₂ O/Fuel	Power Levels	Fuel Quality	Ignition Timing	Spark Plug Heat Range
43/31	100 HP	92 Octane Pump Gas	-2°	Standard to 1 step colder
52/33	125 HP	92 Octane Pump Gas	-2° to 4°	Standard to 1 step colder
59/37	150 HP*	92 Octane Pump Gas w/Octane Booster	-2° to -4°	1-2 steps colder
65/40	175 HP	92 Octane Pump Gas w/Octane Booster	-4° to -6°	1-2 steps colder
71/42	200 HP*	96 Oct. Unleaded Racing Gas or 92 with Octane Booster	-4° to -6°	2 steps colder
76/45	225 HP	96 Oct. Unleaded Racing Gas or 92 with Octane Booster	-6° to -8°	2-3 steps colder
81/47	250 HP*	100 Octane Racing Gas	-6° to -8°	2-3 steps colder
86/50	275 HP*	105 Octane Racing Gas	-8° to -10°	3-4 steps colder
91/52	300 HP	105 Octane Racing Gas	-8° to -10°	3-4 steps colder

* HP Jetting included in kit

NOTE: These kits are very sensitive to fuel pressure and jetting changes. Use only the flare jets (precision stainless steel) provided. Maintain 40-45 psi **flowing** fuel pressure. Spark plug inspection and/or the use of a wide-band O₂ sensor can determine optimum system performance. Inspection of the spark plugs should be done on a consistent basis.

4.1.1 Determining Optimum System Performance

1. Perform a dynamometer pull or a full throttle pass down the racetrack. Note the power reading or vehicle mph (not e.t.). Examine the spark plugs for an indication of lean or rich nitrous/fuel conditions (refer to Figure 8 for tips on reading the spark plugs). For this application, the air/fuel mixtures at WOT tend to be very rich in stock form. You may wish to examine a plug after a NO-nitrous pass or dyno pull for comparison purposes.

CAUTION! Terminate test immediately if pinging, knocking, detonation is noticed during the test. If engine does not pull hard (expected HP or torque gains are not observed), terminate test and investigate before continuing.

- 1A. If spark plugs appear to be excessively rich, decrease the fuel jet size 1 step (ex. 28 to 26 or 26 to 24).
 - 1B. If spark plugs appear to be excessively lean, increase the fuel jet size 1 step.
 - 1C. If spark plugs have a “like new” appearance on the porcelain and electrode, do not make a fuel jetting change.
2. Repeat these steps until the desired mixture is obtained.

How to Read Spark Plugs from a Nitrous Oxide Injected Engine

A. Correct Timing, Mixture, and Spark Plug Heat Range

The ground strap retains a “like new” appearance. The edges are crisp, with no signs of discoloration. The porcelain retains a clear white appearance with no “peppering” or spotting.

B. Excessively Rich Mixture

The porcelain may be fuel stained, appearing brown or black. In extreme cases, the ground strap, electrode, and porcelain may be damp with gasoline, or smell of fuel.

C. Detonation

The edges of the ground strap may become rounded. The porcelain has the appearance of being sprinkled with pepper, or may have aluminum speckles. During heavy detonation, the ground strap tip may burn off. This phenomenon can result from excessive ignition timing, too high a heat range spark plug, inadequate fuel octane, or excessively lean mixture.

D. Excessively Lean Mixture

The edges of the ground strap may become rounded. Under moderate overheating, the tip of the ground strap can discolor, usually turning purple, or the entire ground strap can become discolored.

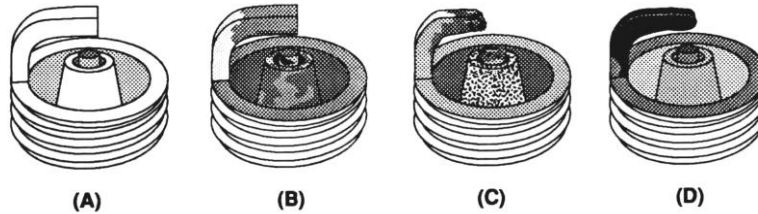

Figure 8 Spark Plug Condition

4.2 Advanced Tuning for Maximum Power

IMPORTANT: Ignition timing should be retarded approximately 1.5 to 2 degrees per 50 HP increase when using nitrous oxide injection. Use initial settings that are 2-3 degrees more retarded than you expect to be optimum.

NOTE: The optimum ignition timing for your vehicle will probably vary somewhat from the guidelines giving. Use these guidelines as safe starting conditions.

4.2.1 Determining Optimum Ignition Timing

The following scheme for determining ignition timing should allow you to determine the optimum setting for your vehicle, without incurring engine damage during the tuning phase.

1. Estimate the reduced ignition timing that you think will produce the best power, based upon the 1.5 to 2 degree retard per 50 horsepower increase rule.
2. Set the ignition timing 2 to 3 degrees retarded from your best power estimate setting.

NOTE: Nitrous bottle pressure should always be set to the same level at the start of each run. NOS systems are calibrated to run at nitrous pressure levels of 900 to 950 psi.

3. Perform a dynamometer pull or a full throttle pass down the racetrack. Note the power reading or vehicle mph.
4. Increase the ignition timing 2 degrees.
5. Perform a dynamometer pull or a full throttle pass down the racetrack. Note the power reading or vehicle mph. Examine the spark plugs for signs of detonation.
 - 5A. If power increases or vehicle mph increases **and** spark plugs show no sign of detonation, increase the ignition timing 2 more degrees.
 - 5B. If power increases or vehicle mph increases **and** spark plugs begin to show slight signs of detonation (very light peppering or speckling on the porcelain)—STOP. Do not advance the timing further. You may choose to reduce the timing 2 degrees at this point for an extra margin of safety.
 - 5C. If power decreases or vehicle mph decreases, reduce the ignition timing 2 degrees.
6. Repeat step 5 until optimum ignition timing is obtained.

Appendix A Troubleshooting Guide

The troubleshooting chart on the following pages should help determine and rectify most problems with your installed NOS system. If you still need assistance determining or fixing problems, call the NOS Technical Support at 1-866-464-6553.

PROBLEM	POSSIBLE CAUSES	DIAGNOSTIC PROCEDURE	CORRECTIVE ACTION
No change in performance when system is activated.	In-line fuse blown.	Check fuse.	Replace fuse.
	System wired incorrectly.	Compare nitrous wiring to schematic (Figure 5).	Wire system per instructions.
	Loose ground wire(s).	Connect 12V test light to battery (+) terminal. Check for continuity at grounds shown in Figure 5.	Tighten/repair loose ground(s).
	Malfunctioning arming switch.	With vehicle ignition ON, turn the arming switch ON. Connect 12V test light to battery (-) terminal. Check for power at red wire on arming switch.	Replace arming switch.

	Malfunctioning throttle microswitch.	Close N ₂ O bottle. Empty N ₂ O supply line. Remove the fuel solenoid shell. Turn ignition ON. Turn arming switch ON. Short across terminals on microswitch, N ₂ O solenoid should “click”.	Replace throttle microswitch.
Engine detonated mildly when system is activated.	Excessive ignition timing.	Check ignition timing.	Retard ignition timing.
	Inadequate octane fuel.		Use higher-octane fuel.
	Spark plug heat range too high.		Reduce spark plug heat range (max. two steps).
	Too much nitrous flow.		Reduce nitrous jetting.
Engine detonated heavily when system is activated.	Inadequate fuel delivery due to: Plugged fuel filter.	Inspect fuel filter.	Clean or replace filter.
	Crimped fuel line.	Inspect fuel line.	Replace crimped line.
	Weak fuel pump	Install fuel pressure gauge in the fuel line. Run engine under load at wide-open throttle with the system activated. Fuel pressure should be at least 38 psi.	Replace fuel pump.
High-rpm misfire when system is activated.	Excessive spark plug gap.	Inspect spark plugs.	Set spark plug gap to 0.030 to 0.035”.
	Weak ignition/ignition component failure.	Inspect components (plug wires, distributor cap, etc.).	Replace worn components.
Surges under acceleration when system is activated.	Inadequate supply of nitrous.	Check bottle weight.	Fill bottle. 1-800-99-REFILL
	Bottle mounted incorrectly.	Compare bottle position and orientation to instructions.	Mount or orient bottle correctly.

Nitrous Oxide Accessories

NOS systems are calibrated for optimum performance with a bottle pressure of 900-950 psi. The pressure will change with temperature. Heater kits are thermostatically controlled to keep the bottle near 85° F to provide correct pressure. **Bottle Heater (P/N 14164NOS)** is available for 10 & 15 lb. bottles.

Insulating the bottle helps maintain pressure by keeping heat in the bottle when it's cold, or heat out when it's hot outside. The blankets are made of a rugged, easily cleaned Nylon outer shell with insulation. It's also an excellent “dress up” accessory and perfect for “covering” battle-scarred bottles. **Bottle Blanket (P/N 14165NOS)** is a 7” diameter blanket for the 10 lb. bottle.



P/N 14164NOS



P/N 14165NOS

With the 35 PSI **Adjustable Pressure Switch (P/N 15686NOS)**, you won't be blasting nitrous into the engine if the fuel pressure is below what is required to supply the required extra fuel. This fuel pressure safety switch can be adjusted to any desired setting, but is preset to 35 PSI at the factory.



P/N 15686NOS

The primary purpose of a **Purge Valve, P/N 16030NOS**, is to release trapped air or gaseous nitrous from the feed line(s). This helps to ensure consistent performances. And, purging looks cool too!

Nitrous Pressure Gauges (P/N 15910NOS) measure from 0-1500 psi (although recommended level is 900-950 psi) and are essential in monitoring the bottle.

The **Quick Release Hinged Aluminum Bracket, P/N 14140NOS**, is available for 10 lb. and 15 lb. bottles. **P/N 14147NOS** is available for the carbon fiber bottle.



P/N 16030NOS



P/N 15910NOS



P/N 14140NOS

For those who want the ultimate in appearance, NOS offers many popular bottles that are fully polished. **P/N 14745-PNOS** is our 10 lb. fully polished bottle.

For optimum weight reduction and distinctive high-tech looks, these DOT-approved NOS carbon fiber-wrapped bottles are it! It weighs about half of the standard bottle (empty). **P/N 14748NOS** has 12.8 lb. capacity.



P/N 14745-PNOS

NOS TECHNICAL SUPPORT
Tech Service: 1-270-781-9741
Toll Free: 1-866-464-6553

For online help, please check the Tech Service section of our website: www.holley.com

199R10329
Revision Date: 3-23-16