



MTX-D, Boost/Shift Gauge



1	Mounting and Sensor Installation.....	3
1.1	Mounting the Gauge.....	3
1.2	MAP sensor.....	3
2	Wiring	3
2.1	Main Gauge Wiring	3
2.2	MAP sensor wiring	4
2.3	Tach signal wiring	4
3	Programming the Gauge (LM Programmer)	4
3.1	Installing the LM Programmer Software	5
3.2	Hooking up the MTX Boost/Shift gauge to the computer	5
3.3	Programming the Gauge.....	5
3.4	Pressure Tab.....	6
3.5	RPM Tab	7
3.6	Display Tab	7
3.7	Updating the Firmware.....	8
4	LogWorks	9
4.1	Connecting the MTX Boost/Shift gauge to other MTS products.....	9
4.2	Logging data	9
5	Changing the MTX gauge face and/or bezel	10
	Appendix A: Limited Warranty.....	11
	Revision History.....	12

1 Mounting and Sensor Installation

1.1 Mounting the Gauge

The MTX Boost/Shift gauge fits in a standard 2-1/16" (52mm) hole. The gauge can be mounted into a commercially available 2-1/16" (52mm) gauge pod or by drilling a 2-1/16" (52mm) diameter hole to your desired mounting location. Check behind the mounting location for any wiring or components before drilling. Allow at least 2-1/4" (57mm) of depth for the gauge body and associated wiring. Mounting of the gauge should be done in such a manner that the cables are not being forcefully pulled from the gauge body itself.

The MTX Boost/Shift gauge is splash resistant (not water proof) and can be mounted so that it is exposed to the elements. The MTX gauge should not be submerged and special consideration should be taken to protect the gauge from direct water spray (water coming from a pressurized source.) When replacing the bezel and/or gauge face verify that the o-ring is properly seated.



Make sure mounting location does not impair visibility or interfere with driving.

1.2 MAP sensor

1. **The MAP sensor MUST be installed with the hose fitting facing down.** It is very important that the sensor be isolated from heat sources, mounted away from all ignition and/or other potential RF emitting sources, and protected against excessive vibration.

The MAP sensor has two 1/8" holes that can be used to secure the sensor. Another viable option to mount the sensor is to use double-sided mounting tape.

2. Locate a vacuum source on the intake manifold, after the throttle body and connect it to the hose fitting on the sensor. Use the provided "T" and hose to make this connection if needed. To secure the hose use tie-wraps or hose clamps.

2 Wiring

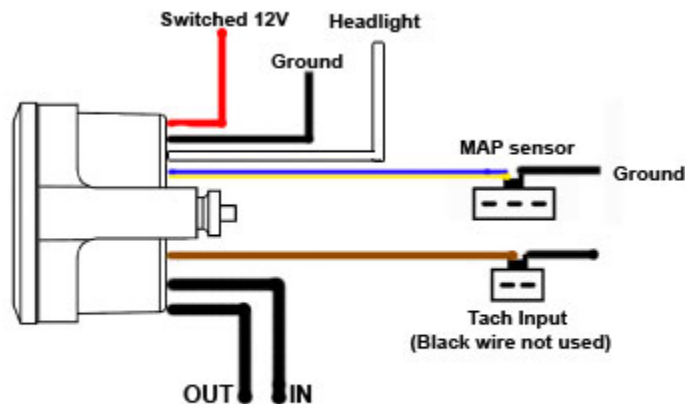

2.1 Main Gauge Wiring

1. Connect the **RED** wire to a switched 12V source. A switched 12V source comes ON as soon as the ignition on the car is keyed on. Make sure the connection is fused with a minimum fuse size of 2A.



Circuits that share power with the vehicle's stereo, ignition system, and fuel pump are not recommended.

2. Connect the main **BLACK** wire to a ground source. Note that there are other black wires coming out of the 2 pin and 3 pin connectors, these are not the main gauge grounds. Avoid noisy ground sources, such as grounds used for the radio and or ignition.
3. Connect the **WHITE** wire to a headlight power wire (a wire that supplies current when the headlights are on). This enables the display to dim for better nighttime viewing. **DO NOT CONNECT THIS WIRE TO THE HEADLIGHT DIMMING WIRE.** Connection to this rheostat type of switch will cause the gauge to malfunction. If you chose not to utilize the dimming feature, connect this WHITE wire to ground.

2.2 MAP sensor wiring

- 1 Fish the MAP sensor's three pin connector through the firewall and to the MTX Boost/Shift gauge.
- 2 Connect the sensor's male three pin connector to the female 3 pin connector on the gauge.
- 3 Coming out of the female three pin connector you will find a black wire with a stripped end. Connect this black wire to the same ground source as the gauge.

2.3 Tach signal wiring

1. The two pin connector with a red wire is the tach input for the shift light. A tach signal can be acquired from the negative lead of a coil, ECU, negative lead of an injector, or ignition box (i.e. MSD 6AL). Connect the tach signal to the red wire of the 2 pin connector extending the wire as needed.

Note: Ignitions running a multi-spark setup (i.e. MSD 6AL) must use the provided tach signal from the ignition box.



A tach signal can not be acquired from the negative lead of the coil on vehicles with CDI ignitions. For these applications use the negative lead of an injector or a tach adapter (if available for your model ignition).

2. Connect the sensor's male two pin connector to the female two pin connector on the gauge.
3. Coming out of the female two pin connector you will find a black wire with a stripped end. **Do not** use this wire, isolate and tuck it away.

3 Programming the Gauge (LM Programmer)

The MTX Boost/Shift gauge is programmable with the following functionality:

1. Change the display unit of measure from Imperial to Metric
2. Configure the RPM pulses per rotation
3. Setup alarms and warnings
4. Setup shift light modes/parameters
5. Upgrade the firmware



Avoid connecting or disconnecting any of the ports labeled IN or OUT while the unit is powered ON.

3.1 Installing the LM Programmer Software

Put the included CD in your CD-drive on your computer and follow the instructions on screen. The installer includes LogWorks, LM Programmer, manuals, and other tools.

3.2 Hooking up the MTX Boost/Shift gauge to the computer

1. Power OFF the MTX Boost/Shift gauge
2. Connect the supplied serial cable to the port labeled OUT.
3. There should be nothing connected to the port labeled IN.
4. Power ON the MTX Boost/Shift gauge.
5. Connect the serial cable to your computer. If you are using a serial to USB adapter, connect the serial cable to the adapter then connect the adapter to the computer.
6. Launch LM Programmer. The LM Programmer application can be launched from *Start->Programs->LogWorks3->LM Programmer* from the Windows task bar.

3.3 Programming the Gauge

Whenever a change is made to the programming of the gauge click the **Program** button for the change to take effect. Once the gauge has been programmed the **Program** button will grey out.

To set the gauge back to the factory settings click the **Set To Defaults** button and then click the **Program** button.

3.4 Pressure Tab

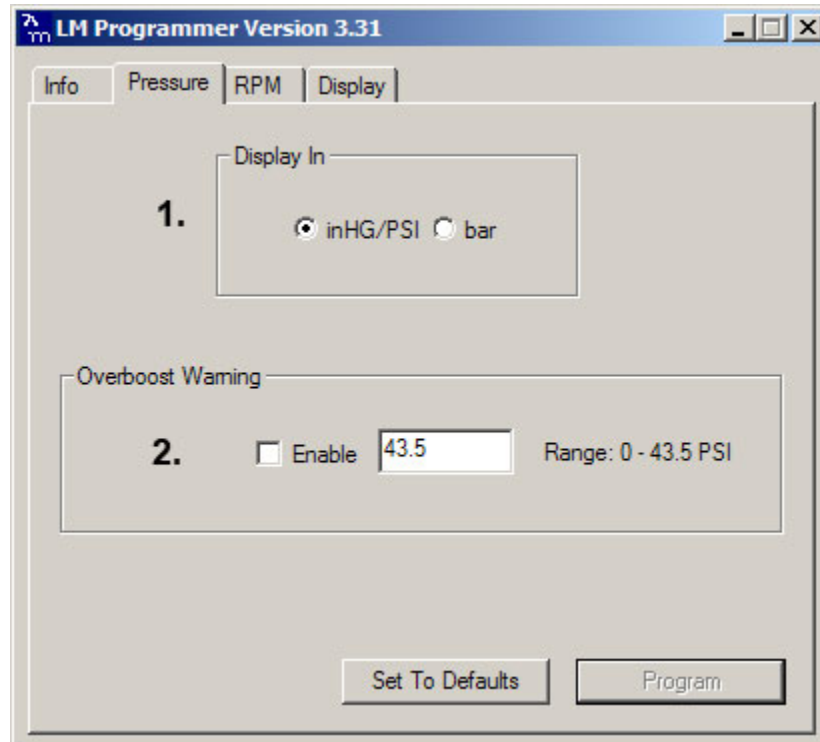

1. **Display In** allows the gauge to display Boost in either Imperial or Metric units of measure.
2. The **Overboost Warning** will enable the gauge's seven segment display to flash when the entered threshold value has been exceeded. To enable this feature the "Enable" option must be checked.

3.5 RPM Tab

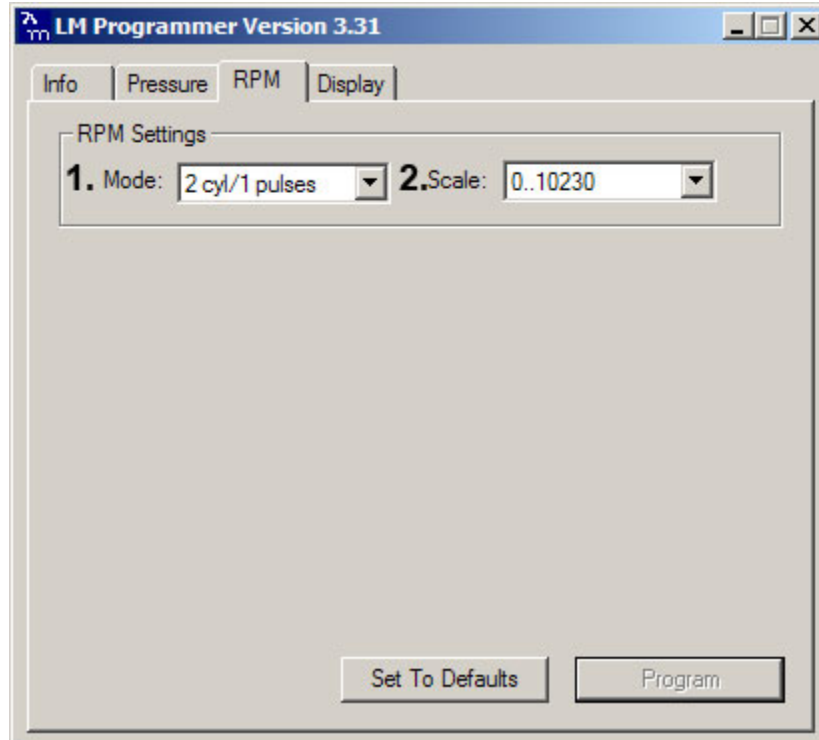

1. **Mode:** Select how many pulses per rotation based on your tach signal source
2. **Scale:** Select the RPM scale. Options are 10230 RPM or 20460 RPM. Selected 20460 RPM if your engine rev passed 10230 RPM.

3.6 Display Tab

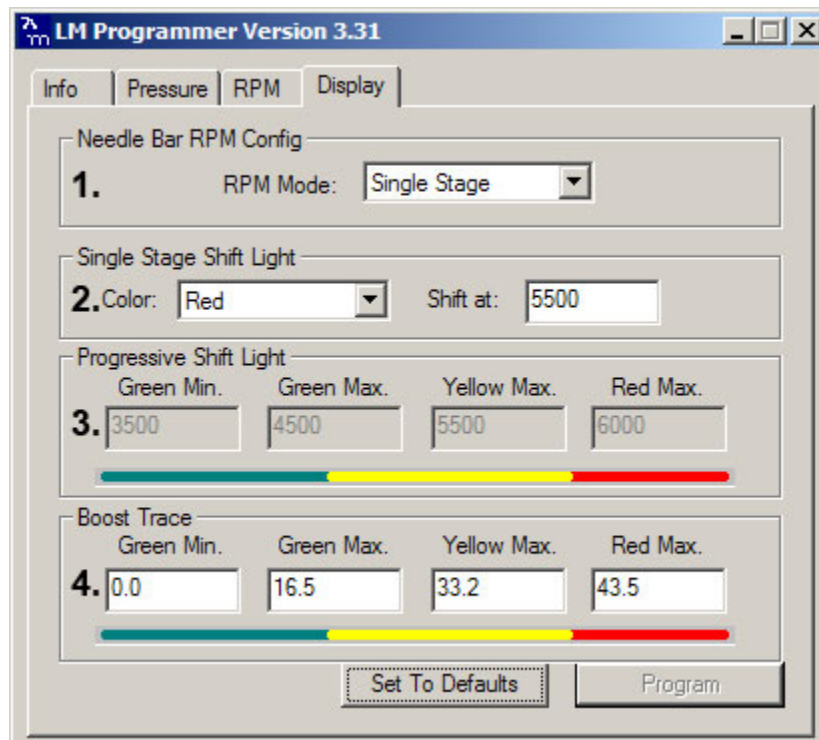

1. **Needle Bar RPM Config:** You are able to select between Single Stage or Progressive shift light.

Single Stage allows the gauge's outer LEDs to flash each individual LED color segment or all at a specific threshold. While Single Stage is selected, Boost Trace is enabled.

Progressive allows the gauge's outer LEDs to flash incrementally. Boost Trace is disabled when the Progressive shift light is enabled.

2. **Single Stage Shift Light:** Allows the configuration of either Green, Yellow, Red, or All LED segments to flash at the desired shift threshold. This selection is enabled when Single Stage is selected in Needle Bar RPM Config.
3. **Progressive Shift Light:** Allows the configuration of the progressive shift light at each outer LED segment. This selection is enabled when Progressive is selected in Needle Bar RPM Config.
4. **Boost Trace:** Allows the configuration of the progressive shift light at each outer LED segment. Boost Trace is enabled when Single Stage is selected. In addition to the Single Stage shift light a single LED (virtual needle) will be illuminated indicating the boost level. The Boost range displayed is user defined.

3.7 Updating the Firmware

The LM Programmer Info tab reports the firmware version currently installed on your unit. **Do not update the firmware if the versions are the same. A firmware update should only be necessary if there has been a new release that specifically fixes a problem that you are experiencing with the unit.**

Firmware for the MTX Boost/Shift gauge has the extension dld. New firmware releases are available for download on the Innovate Motorsports' web site (www.tuneyouengine.com) under 'Support.'

1. Power OFF the MTX Boost/Shift gauge
2. Connect the supplied serial cable to the port labeled OUT.
3. There should be nothing connected to the port labeled IN.
4. Power ON the MTX Boost/Shift gauge.
5. Connect the serial cable to your computer. If you are using a serial to USB adapter, connect the serial cable to the adapter then connect the adapter to the computer.
6. Launch LM Programmer. The LM Programmer application can be launched from *Start->Programs->LogWorks3->LM Programmer* from the Windows task bar.
7. Once connected the LM Programmer will display the current version of the firmware that is installed in the LM-2. Do not update the firmware if the versions are the same. A firmware update should only be necessary if there has been a new release.
8. On the very first tab of LM Programmer you will see a button labeled "Update Firmware," click this button.
9. Select the firmware file with the dld extension.
10. Do not disconnect the unit from the computer until the firmware progress screen completely disappears. Once finished you may disconnect the unit from the computer and exit out of the software.

If your computer crashes during a firmware upgrade, the MTX Boost/Shift gauge has a recovery mechanism where it will be able to retry the download again and not be disabled by half loaded firmware. Switch the MTX Boost/Shift gauge off and on again and then reload LM Programmer. The recovery mechanism is designed to be able to recover 99.9% of the time. While we don't

anticipate this occurring, it is possible that the MTX will not recover correctly and may need to be serviced at our factory. If you suspect this is the case, contact Innovate support.

4 LogWorks

The MTX Boost/Shift gauge can be connected to the LogWorks software to record and analyze boost and engine RPM. The gauge can also be connected to other Innovate Motorsports products to create a log chain with additional gauges and sensors.

4.1 Connecting the MTX Boost/Shift gauge to other MTS products

The MTX Boost/Shift gauge has a port labeled IN and a port labeled OUT. These connections allow multiple MTS (Modular Tuning System) devices to be connected together in order to form a single log chain.

There are two types of cables used to interface the MTX Boost/Shift gauge. The 3812 cable is a 4 pin micro fit to 2.5mm male stereo plug used. The 3846 cable is a 4pin Micro fit to 4pin Micro fit. These cables are sold separately, make sure to select the correct cables to interface the product you own.

1. Power OFF all your MTS devices.
2. Start with the first product in the serial chain. Using the appropriate mating cable, connect the OUT port from the first device and feed it into the IN port of the second device. *(Note: If you have an LC-1, there must be a terminator plug in the serial IN if it is the first device in the serial chain.)*
3. Continue connecting the OUT port of each device into the IN until all your devices are connected together.
4. If a recording device is not connected to the serial chain, e.g. DL-32, LM-2, the OUT port of the last device can be connected directly to a computer to log with the LogWorks software
5. Once all the connections of the ports labeled IN and OUT are made the MTS devices can be powered ON.

4.2 Logging data

1. Power OFF the MTX Boost/Shift gauge
2. Connect the supplied serial cable to the port labeled OUT.
3. There should be nothing connected to the port labeled IN.
4. Power ON the MTX Boost/Shift gauge.
5. Connect the serial cable to your computer. If you are using a serial to USB adapter, connect the serial cable to the adapter then connect the adapter to the computer.
6. Launch LogWorks. The LogWorks application can be launched from *Start->Programs->LogWorks3->Logworks3* from the Windows task bar.
7. Once LogWorks launches go to *File->Connect*. You will be prompted to connect to serial COM port. Click Connect.
8. To start recording go to *File->New Real-time Log* or, in the Toolbar, click on the  Tool.

5 Changing the MTX gauge face and/or bezel

1. Lay the MTX gauge face down and remove the three #2 phillips screws from the outside rim of the back plate.
2. Carefully lift off the bezel from the gauge cup.
3. Configure the gauge as desired by changing the gauge face and or bezel.
***Be sure to remove protective film from the gauge face. This can be done easily with a piece of scotch tape.**
4. Make sure every piece is positioned correctly using the locating tab and reassemble the gauge.
5. Reinstall the 3 #2 phillips screws.

Appendix A: Limited Warranty

LIMITED WARRANTY

Innovate stands behind the quality of its products. Innovate makes the following warranty to purchasers of its products: All new Innovate products carry a one year warranty from the date of purchase. If proof of purchase cannot be provided, warranty will be determined by date of manufacture.

When Warranty Void

This warranty shall terminate and Innovate shall have no obligation pursuant to it if (i) your Innovate product has been modified or repaired in a manner not previously authorized by Innovate in writing, (ii) the identification markings on your Innovate product have been removed, defaced, or altered; (iii) your Innovate product was subjected to accident, abuse, shipping damage, or improper use; (iv) your Innovate product was not used or configured as specified in the product manual; or (v) your Innovate product was subjected to operating conditions more severe than those specified in the product manual.

Exclusions From This Warranty

Oxygen Sensors are excluded from this warranty.

Repairs Under This Warranty

In the unlikely event that your Innovate hardware product should prove defective during the warranty period, contact Innovate Customer Support for a return material authorization (RMA) at (800) 348 3037. Products returned for service must be securely packed to prevent damage and shipped charges pre paid, along with proof of purchase and the return material authorization form, to the Innovate repair location as instructed by Customer Service. Innovate within a reasonable amount of time from its receipt of your product so shipped, will ship to you, at its option, the repaired product or a new or reconditioned product of comparable or greater specified functionality. All repaired or replacement products shall be warranted for the remainder of the original product warranty.

Disclaimer

INNOVATE MAKES NO OTHER EXPRESS OR IMPLIED WARRANTY WITH RESPECT TO YOUR INNOVATE PRODUCT OTHER THAN THE LIMITED WARRANTY SET FORTH ABOVE. No Innovate dealer, agent, or employee is authorized to make any modification, extension, or addition to this warranty, unless enforceable or unlawful under applicable law, INNOVATE DISCLAIMS ALL IMPLIED WARRANTIES, INCLUDING THE IMPLIED WARRANTIES OF MERCHANTABILITY, NONINFRINGEMENT, AND FITNESS FOR A PARTICULAR PURPOSE, AND THE LIABILITY OF INNOVATE, IF ANY, FOR DAMAGES RELATING TO ANY ALLEGEDLY DEFECTIVE PRODUCT SHALL UNDER ANY TORT, CONTRACT, OR OTHER LEGAL THEORY BE LIMITED TO THE ACTUAL PRICE PAID FOR SUCH PRODUCT AND SHALL IN NO EVENT INCLUDE INCIDENTAL, CONSEQUENTIAL, SPECIAL, OR INDIRECT DAMAGES OF ANY KIND EVEN IF INNOVATE IS AWARE OF THE POSSIBILITY OF SUCH DAMAGES. Some states do not allow limitations on how long an implied warranty lasts or the exclusion or limitation of incidental or consequential damages, so the above limitations or exclusions may not apply to you.

Revision History

1.0 – 4/5/2012

Initial release.

1.1 – 5/4/2012

Added addition screen shots and wiring diagram