

MSD IGNITION INSTALLATION INSTRUCTIONS

6LS-2 Harness for EFI Vehicles PN 88862

IMPORTANT: Read instructions thoroughly before attempting installation.

Parts Included:

1 - Cam Sensor Harness	2 - Coil Simulator Clips
1 - Crank Sensor Harness	1 - Crank Sensor Tool Body
1 - Map Sensor Harness	1 - Crank Sensor Tool Blade
2 - Coil Simulators	2 - 6-32 x .250 Screws

WARNING: Before installing the 6LS-2 Harness, disconnect the battery cables. When disconnecting the battery cables, always remove the Negative (-) cable first and install it last.

This Harness Kit allows the installation of the MSD 6LS-2 Ignition Controller on LS2 or LS7 based vehicles equipped with factory EFI systems. The Harness connects inline to factory sensors and provides the 12 volt supply and ground of the Controller.

COIL CONNECTIONS

Note: One of the Coil Simulators has a 3-Pin pigtail. This assembly connects to the passenger side coil bank.

Disconnect the factory connector from the coil harness (Figure 1). Connect the MSD Coil Simulators inline with the factory harness. Use the supplied clips to secure the Simulators.

Connect the 3-pin pigtail to the MSD 6LS-2.

Note: The 3-pin harness with the ring lug terminal, part of the MSD 6LS-2 is not used with PN 88862.

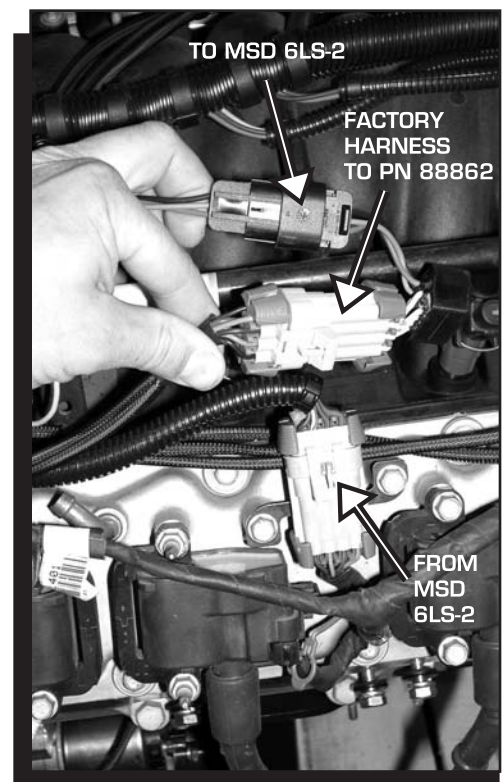
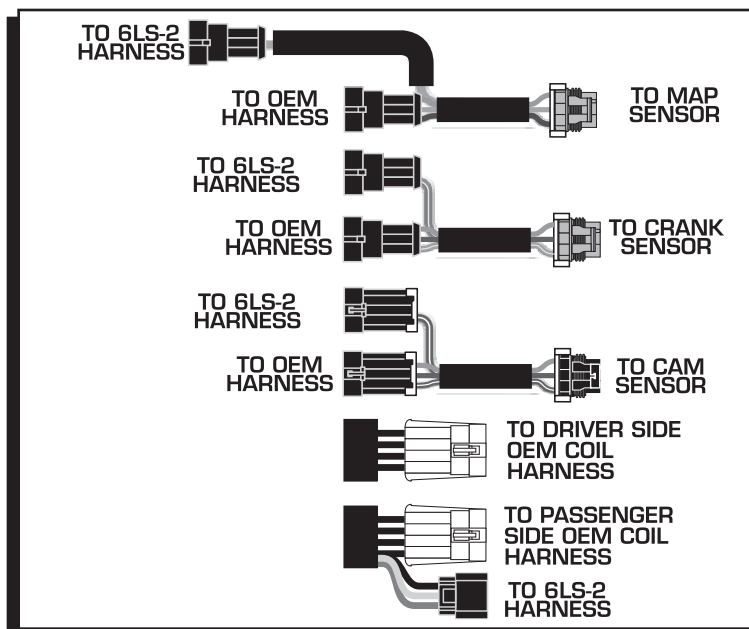

Figure 1 Coil Connections.

MAP SENSOR

Disconnect the MAP sensor harness and install the MSD Harness inline. The Gray Connector of the Harness goes to the MAP sensor. Connect the MAP connector of the 6LS-2 into the connector with a single signal wire (Figure 2).

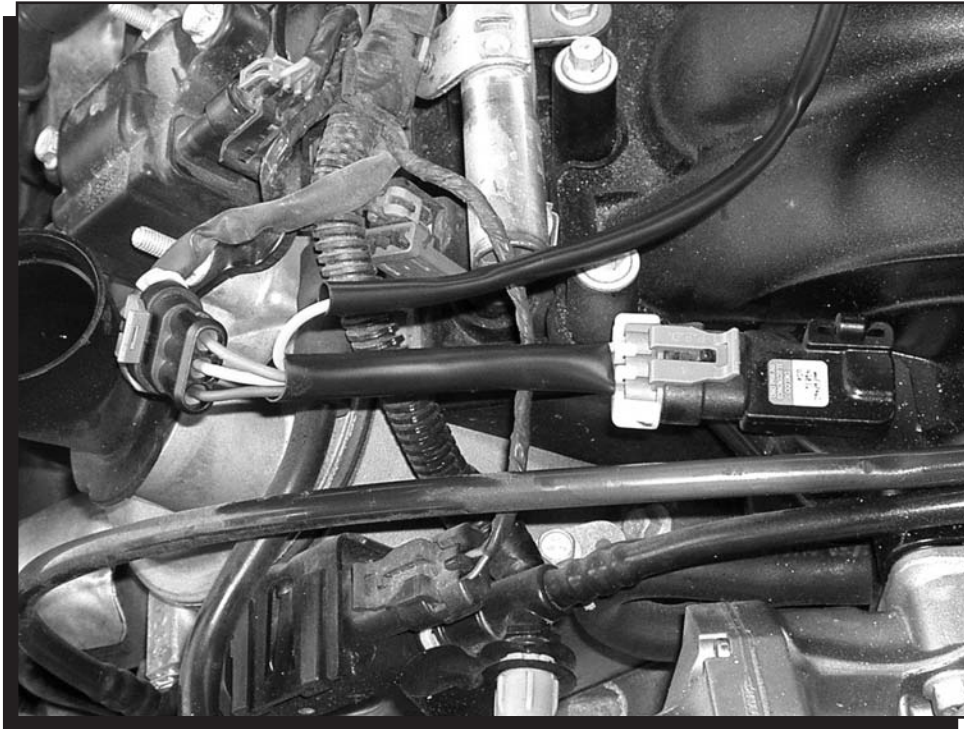

Figure 2 Map Sensor Connection.

CAMSHAFT SENSOR

Locate the Camshaft Sensor and the extension cable. On LS2/LS7 based engines, the Cam Sensor is on the front of the block.

Disconnect the extension cable from factory harness and install the MSD Harness (Black connector) inline. Connect the Cam Connector of the 6LS-2 to the connector with a single signal wire.

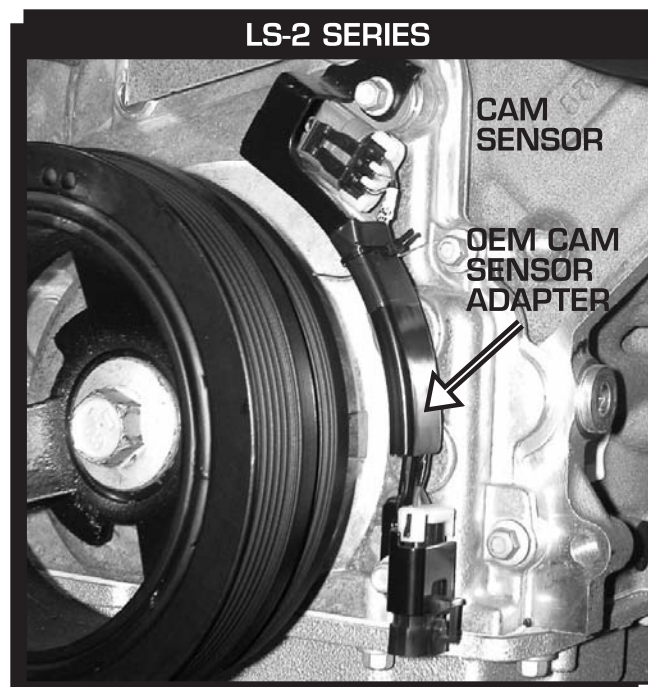

Figure 3 Camshaft Sensor Location.

CRANKSHAFT SENSOR

This sensor is located just above/behind the starter. If the engine is in the car, you will need to assemble the supplied special tool to access the sensor connector (Figure 4), or remove the starter. If the engine is out of the car the sensor should be easy to reach.

Disconnect the crank sensor and install the MSD Harness with three wires to the factory connectors. Connect the single wire connector to the Crank Sensor connector of the 6LS-2 Control.

CRANKSHAFT CONNECTOR SPECIAL TOOL

This tool will help you access the crankshaft sensor from behind the starter when the engine is in the vehicle.

Assemble the Tool as shown in Figure 5.

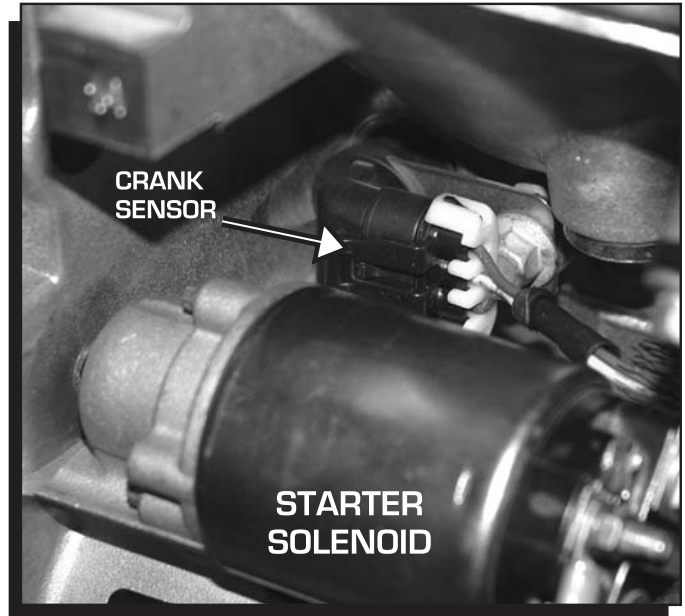

Figure 4 Crankshaft Sensor Location.

1. Insert the tool through the casting hole with the bend in the blade facing the rear of the car.
2. Rotate the tool clockwise about 10-degrees and push the tool further through the casting hole.
3. Rotate the tool clockwise until the blade meets the Connector tab. At this point, push the tool towards the rear of the car in order to disconnect the crank sensor.
4. Use the tool to connect the 3-pin MSD harness connector to the sensor (Figure 6).
5. Connect the factory sensor connector to the MSD harness.
6. Connect the single wire harness to the matching 6LS connector.

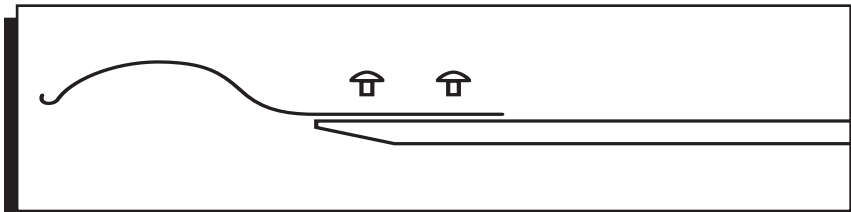

Figure 5 Assembling the Special Tool.

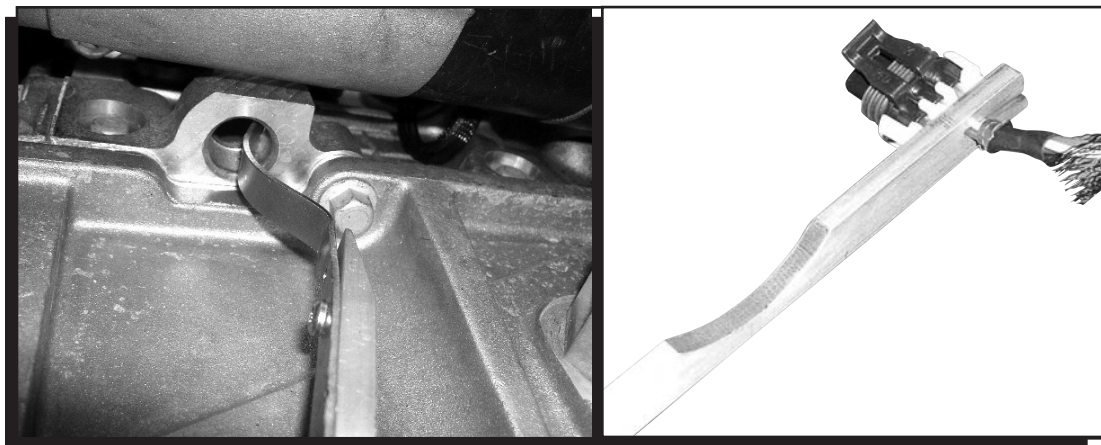

Figure 6 Connecting the Crank Sensor.



INSTALLATION INSTRUCTIONS

NOTES

Service

In case of malfunction, this MSD component will be repaired free of charge according to the terms of the warranty. When returning MSD components for service, Proof of Purchase must be supplied for warranty verification. After the warranty period has expired, repair service is charged based on a minimum and maximum charge.

All returns must have a Return Material Authorization (RMA) number issued to them before being returned. To obtain an RMA number please contact MSD Customer Service at (915) 855-7123 or fax a request to (915) 857-3344. Send the unit prepaid with proof of purchase to the attention of: **MSD Ignition, Customer Service - RMA #, 12120 Esther Lama, Dock 5, El Paso, Texas 79936.**

When returning the unit for repair, leave all wires at the length in which you have them installed. Be sure to include a detailed account of any problems experienced, and what components and accessories are installed on the vehicle.

The repaired unit will be returned as soon as possible after receipt, COD for any charges. (Ground shipping is covered by warranty). All units are returned regular UPS unless otherwise noted. For more information, call the MSD Customer Service Line (915) 855-7123. MSD technicians are available from 7:00 a.m. to 6:00 p.m. Monday - Friday (mountain time).

Limited Warranty

MSD IGNITION warrants MSD Ignition products to be free from defects in material and workmanship under normal use and if properly installed for a period of one year from date of purchase. If found to be defective as mentioned above, it will be replaced or repaired if returned prepaid along with proof of date of purchase. This shall constitute the sole remedy of the purchaser and the sole liability of MSD Ignition. To the extent permitted by law, the foregoing is exclusive and in lieu of all other warranties or representations whether expressed or implied, including any implied warranty of merchantability or fitness. In no event shall MSD Ignition be liable for special or consequential damages.