



# INSTALLATION INSTRUCTIONS

## Universal Flying Magnet Crank Trigger Kit PN 8655

### Parts Included:

1 - Trigger Wheel, 7.25" Diameter  
1 - Universal Pickup Holder  
1 - Universal Bracket  
2 - Washers, 5/16"

1 - Pickup Holder Base  
1 - Non-Magnetic Pickup, PN 8276  
2 - Bolts, 5/16 - 24 x 1.25"  
6 - Matched Magnets and Rivets

**Note:** This Kit requires fabrication for your specific application. It is recommended to use a professional machine shop.

### TRIGGER WHEEL

The Trigger Wheel is 3/8" thick aluminum, has a 7.25" diameter and a 1" hole in the center. It has magnet positions machined for up to 12-cylinder applications (six magnets). Figure 1 shows where each magnet needs to be installed depending on the number of cylinders.

The Wheel retaining holes must be machined, as well as a centering method. It is imperative that the wheel be centered accurately.

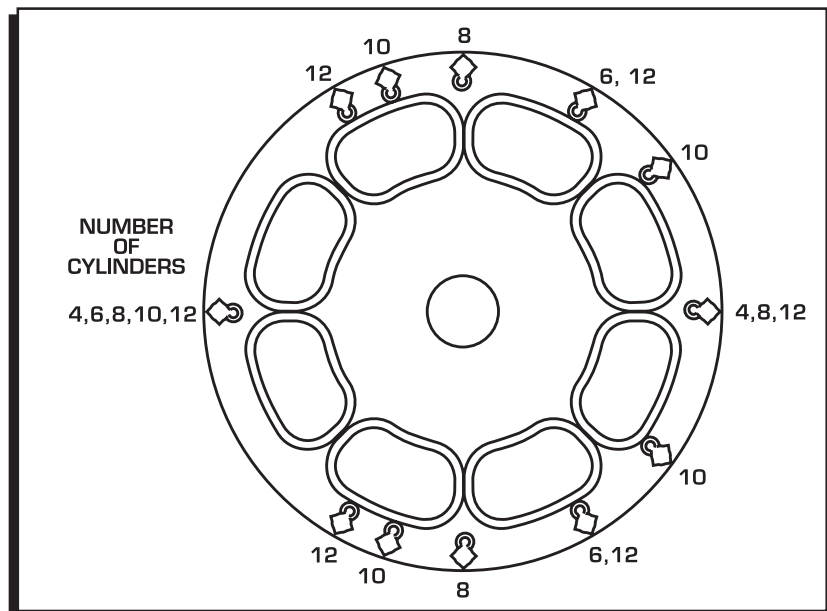

Figure 1 Magnet Location for Different Engine Applications.

### MAGNET INSTALLATION

The magnets that are supplied are a matched set and must be installed in one position to produce the correct trigger signal.

1. Determine which side of the wheel will face out. Mark this position.
2. Install the magnet in the wheel with the hole in the plastic overmolding facing out from the engine (Figure 2). The chamfer on the magnet must be positioned next to the aluminum rivet.
3. Install the rivet. It must be set by using a press or vice with a set of smooth, parallel jaws (such as the vice on a milling machine).

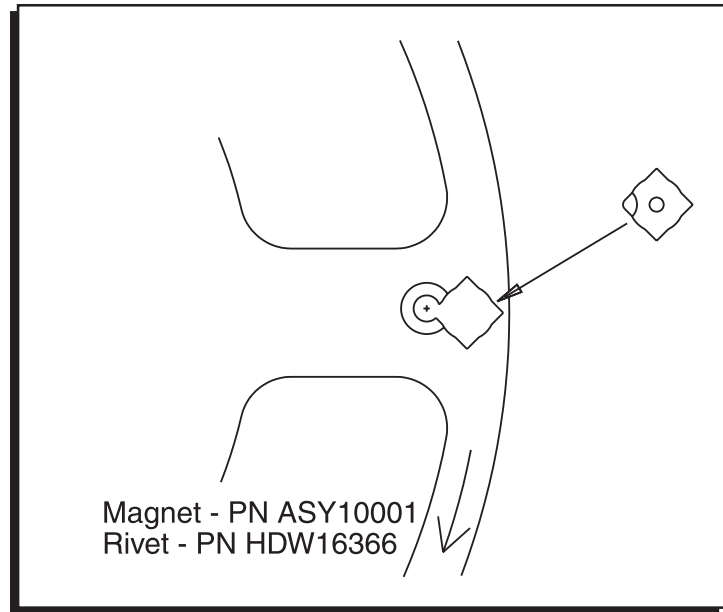

Figure 2 Installing the Magnets.

### BRACKET AND PICKUP MOUNT

Once the Trigger Wheel mounting is complete, the brackets need to be created. The mounting bracket can be cut and machined to meet your requirements. Consider these tips when machining the bracket:

- It is required to have at least two retaining bolts to secure the bracket.
- Do not mount the bracket flush to the block. It will be necessary to be able to install the pickup holder bolt retainer behind the bracket.
- The pickup must be spaced  $5/8$ " away from the trigger wheel (Figure 3). This is required so the air gap between the pickup and trigger wheel will remain constant through its adjustment range.

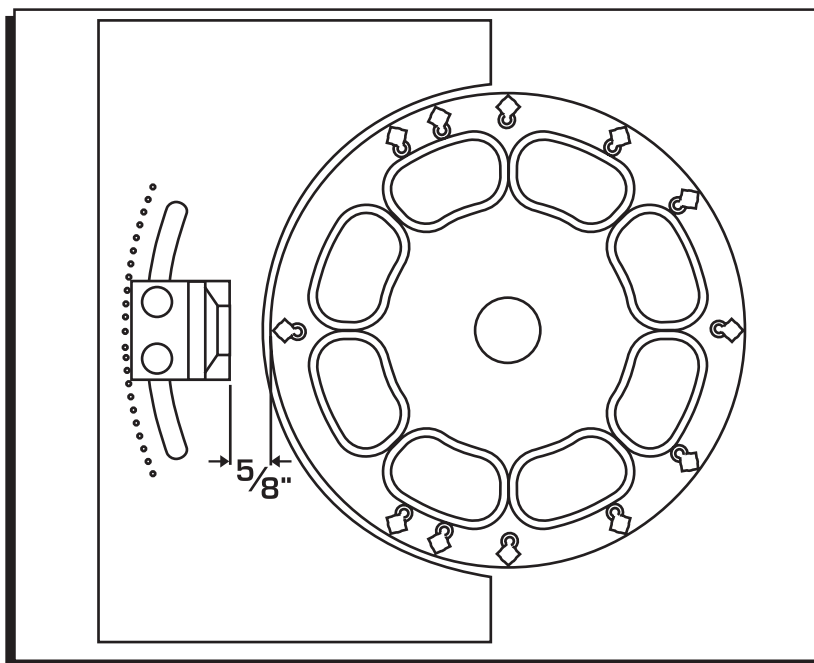
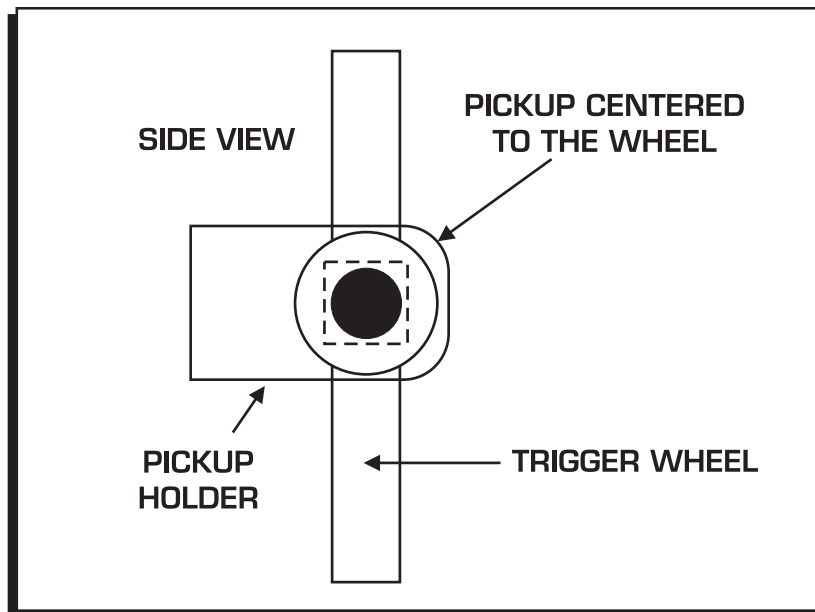

Figure 3 Pickup Bracket Placement.

**PICKUP HOLE**

To machine the Pickup Holder, the bracket and trigger wheel must be installed. This is necessary to center the Non-Magnetic Pickup to the trigger wheel (Figure 4).

1. Bolt the Pickup Holder to the bracket.
2. Locate the center of the trigger wheel and mark this location on the Pickup Holder.
3. Use an 11/16" drill bit, and tap the hole to 3/4-16 threads.
4. Install the pickup and lock nut. Set the air-gap to .050"-.080" (Figure 5).



**Figure 4 Centering the Pickup Mounting Hole.**

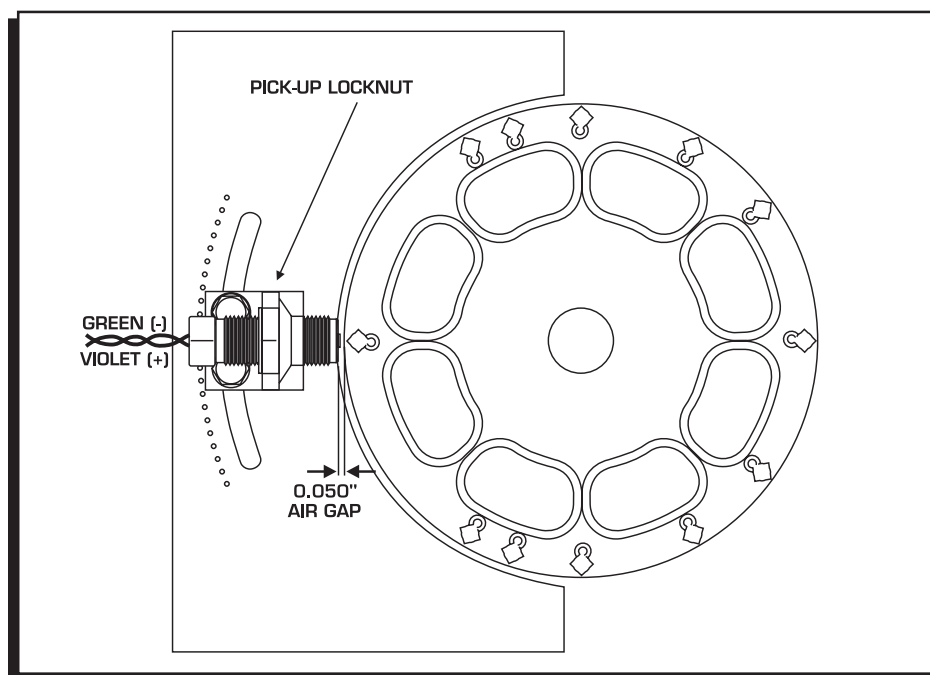

**Figure 5 Setting the Pickup Air-Gap.**



# INSTALLATION INSTRUCTIONS

## Service

In case of malfunction, this MSD component will be repaired free of charge according to the terms of the warranty. When returning MSD components for service, Proof of Purchase must be supplied for warranty verification. After the warranty period has expired, repair service is charged based on a minimum and maximum charge.

Send the unit prepaid with proof of purchase to the attention of: **Customer Service Department, Autotronic Controls Corporation, 12120 Esther Lama, Suite 114, El Paso, Texas 79936.**

When returning the unit for repair, leave all wires at the length in which you have them installed. Be sure to include a detailed account of any problems experienced, and what components and accessories are installed on the vehicle.

The repaired unit will be returned as soon as possible after receipt, COD for any charges. (Ground shipping is covered by warranty). All units are returned regular UPS unless otherwise noted. For more information, call the MSD Customer Service Line (915) 855-7123. MSD technicians are available from 8:00 a.m. to 5:00 p.m. Monday - Friday (mountain time).

## Limited Warranty

Autotronic Controls Corporation warrants MSD Ignition products to be free from defects in material and workmanship under normal use and if properly installed for a period of one year from date of purchase. If found to be defective as mentioned above, it will be replaced or repaired if returned prepaid along with proof of date of purchase. This shall constitute the sole remedy of the purchaser and the sole liability of Autotronic Controls Corporation. To the extent permitted by law, the foregoing is exclusive and in lieu of all other warranties or representations whether expressed or implied, including any implied warranty of merchantability or fitness. In no event shall Autotronic Controls Corporation be liable for special or consequential damages.