

# **MSD** **IGNITION** **INSTALLATION INSTRUCTIONS**

## **MSD Pro-Billet Ford FE Distributor PN 8594**

**Important:** Read these Instructions before attempting the installation.

**Note:** An MSD Ignition is required with this Distributor.

### **Parts Included:**

1 - Pro-Billet Distributor	1 - Advance Kit
1 - Rotor, PN 8467	1 - Tube of Gear Lubricant
1 - Distributor Cap, PN 8433	1 - O-Ring
1 - Wire Retainer	
2 - 1.5" Self Tapping Screws	
2 - 10-32 x 3/4" Socket Head Screws	

**WARNING:** Before installing the MSD Distributor, disconnect the battery cables. When disconnecting the battery cables, always remove the Negative (-) cable first and install it last.

**Note:** The terminals of this Distributor Cap require spark plug style terminals. You may need to change the terminals and boots of your wires. MSD offers two kits, PN 8849 or PN 8848 that are supplied with nine boots and terminals.

**Note:** If you prefer the points style socket cap, MSD offers one as PN 8437.

## **TIMING FUNCTIONS**

Before continuing with the installation, here are a few definitions you should be aware of:

**Initial Timing:** This is the base timing (also referred to as idle timing) of the engine before the centrifugal advance begins.

**Centrifugal Advance:** The centrifugal (or mechanical) advance mechanism is made up of weights, springs, advance cams, and an advance stop bushing. The amount and rate of advance that your distributor is capable of is determined by the centrifugal timing. If you ever wish to lock out the centrifugal advance, refer to the centrifugal advance section.

**Total Timing:** This is the total of the initial timing plus the centrifugal advance added together. Example: 10° Initial + 25° centrifugal = 35° Total Timing.

**Note:** MSD Distributors are supplied with the heavy (slow) advance springs installed. This is to prevent detonation in certain applications. Review the information on pages 2-4 to determine the best advance curve for your application.

## **CHOOSING AN ADVANCE CURVE**

The function of the advance curve is to match the ignition timing to the burning rate of the fuel and speed (rpm) of the engine. Any factor that changes the burning rate of the fuel or the engine speed can cause a need for an ignition timing change. Figure 1 shows some of the factors that will affect engine timing.

<b>FACTOR</b>	<b>Advance Timing For</b>	<b>Retard Timing For</b>
Cylinder Pressure	Low	High
Vacuum	High	Low
Energy of Ignition	Low	High
Fuel Octane	High	Low
Mixture (Air/Fuel)	Rich	Lean
Temperature	Cool	Hot
Combustion Chamber Shape	Open	Compact
Spark Plug Location	Offset	Center
Combustion Turbulence	Low	High
Load	Light	Heavy

**Figure 1 Ignition Timing Factors.**

As you can see from the chart, most factors will change throughout the range of the engine operation. The timing mechanism of the distributor must make timing changes based on these factors.

**Example:** An engine has 11:1 compression with a high energy ignition. With the specifications given, you will have to retard the timing for the high compression and high energy ignition. By comparing the engine's specifications against the chart, a usable timing guideline can be found. Engines with a combination of items from both columns will require a timing that is set in the mid range.

Obviously a full technical explanation of correct ignition timing would be very complicated. The best way to arrive at a suitable ignition curve for your engine is to use the Ignition Timing Factors Chart as a guide and compare it to the Advance Graphs in Figure 4 until a suitable curve is found. When selecting your advance curve, use detonation (engine ping) as an indicator of too much advance, and a decrease in power as an indicator of too little advance.

### **TIPS ON SELECTING AN ADVANCE CURVE**

- Use as much initial advance as possible without encountering excessive starter load.
- Start the centrifugal advance just above the idle rpm.
- The starting point of the centrifugal advance curve is controlled by the installed length and tension of the spring.
- How quickly the centrifugal advance (slope) comes in is controlled by the spring stiffness. The stiffer the spring, the slower the advance curve.
- The amount of advance is controlled by the advance bushing. The bigger the bushing, the smaller the amount of advance.

# CENTRIFUGAL ADVANCE CURVE

## SELECTING THE ADVANCE SPRINGS

The rate, or how quick the advance comes in is determined by the type of springs which are installed on the distributor. The MSD distributors are equipped with two Heavy Silver springs installed. These will give you the slowest advance curve possible (Figure 2). The parts kit contains two additional sets of springs which can be used to match the advance curve to your particular application. Refer to the Spring Combination Chart (Figure 3) for combinations that can be achieved.

To change the springs, remove the cap and rotor and use needlenose pliers to remove the springs. Be sure the new springs seat in the groove on the pin.

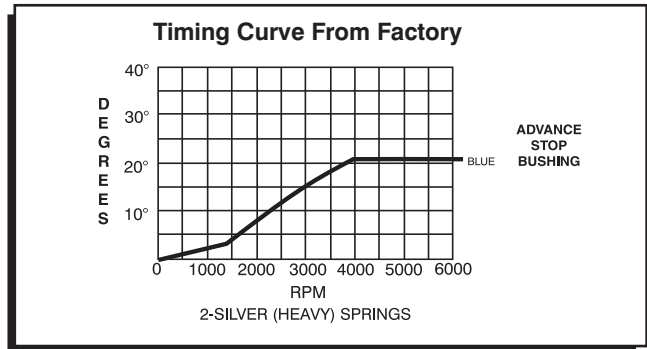

Figure 2 The Factory Equipped Curve.

SPRING COMBINATION	RATE OF ADVANCE	FIGURE 4
2- Heavy Silver	SLOWEST	A
1- Heavy Silver		B
1- Light Blue		C
1-Heavy Silver		D
1-Light Silver		E
2- Light Blue		F
2- Light Silver		FASTEST

Figure 3 Spring Combination Chart.

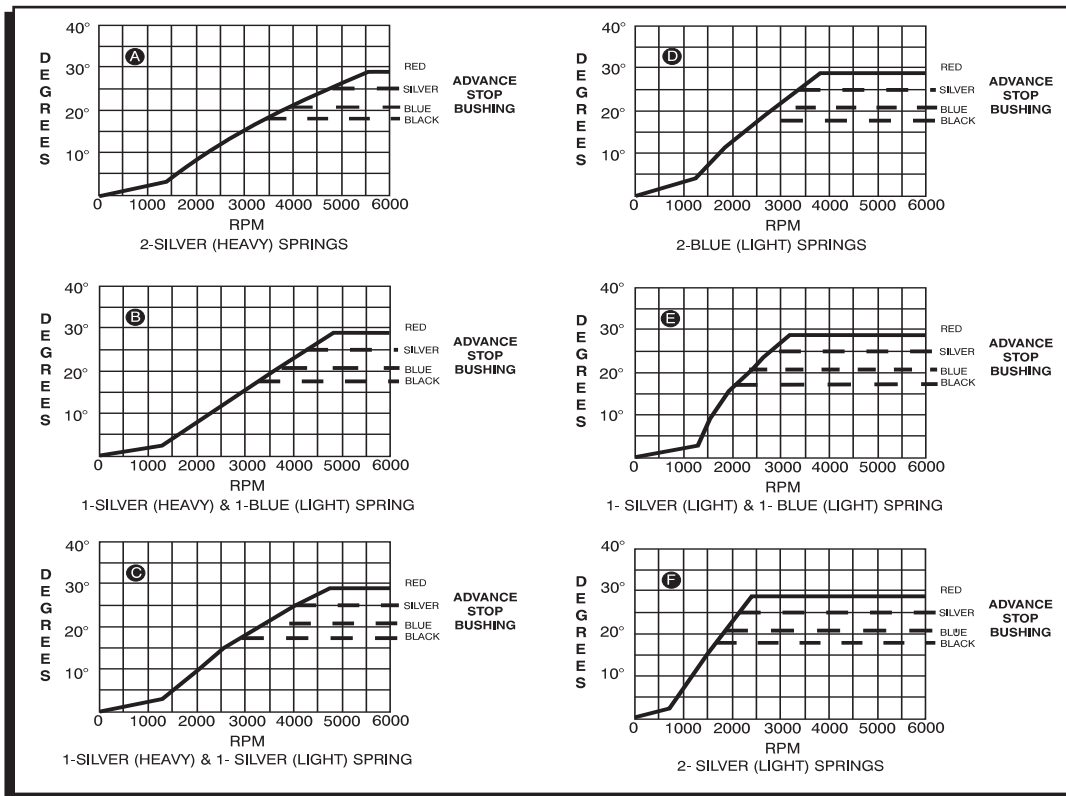

Figure 4 Advance Curves.

## SELECTING THE ADVANCE STOP BUSHING

Three different advance stop bushings are supplied in the distributor kit. The distributor comes with a Blue (21°) bushing already installed. If a different amount of centrifugal advance is desired, follow the next procedure to change the bushings. The chart in Figure 5 gives the size and approximate degrees for the corresponding bushings.

## CHANGING THE ADVANCE STOP BUSHINGS

1. Remove the distributor cap and rotor.
2. Remove the locknut and washer on the bottom of the advance assembly (Figure 6).
3. Remove the bushing and install the new one. Install the washer and locknut.

## LOCKING OUT THE CENTRIFUGAL ADVANCE

1. Remove the advance components including the springs, weights and the advance stop bushing from the advance assembly.
2. Remove the roll-pin from the shaft collar and the drive gear. Remove the gear from the shaft.
3. Slide the shaft two inches out of the housing.
4. Rotate the shaft 180° and insert the advance stop bushing pin into the small hole on the advance plate (Figure 7).
5. Install the locknut and washer to the advance stop bushing pin. This locks the advance in place.
6. Install the shaft collar, drive gear and roll-pins.

BUSHING SIZE	APPROXIMATE CRANKSHAFT DEGREES
Red-Smallest	28
Silver	25
Blue	21
Black-Largest	18

Figure 5 Advance Stop Bushing Chart.

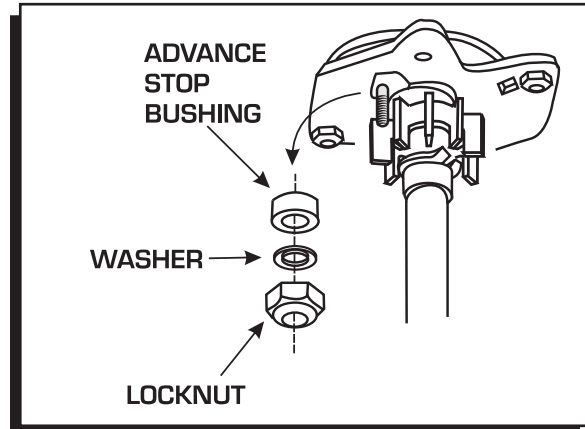

Figure 6 Changing the Advance Stop Bushing.

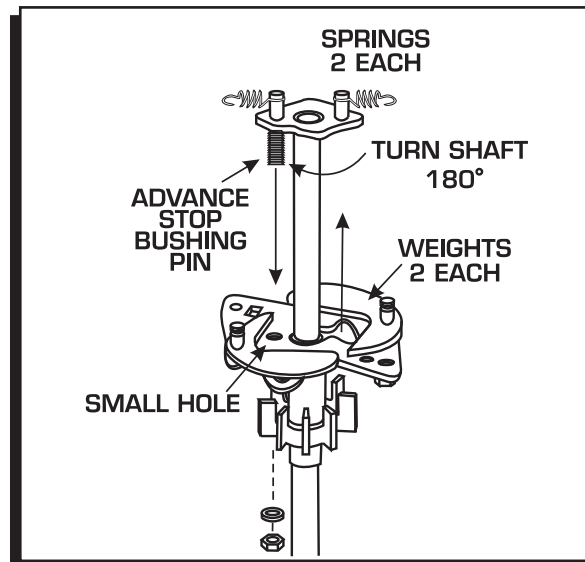

Figure 7 Locking Out the Advance.

## INSTALLING THE DISTRIBUTOR

1. Remove the existing distributor cap without disconnecting any of the spark plug wires.
2. With the cap off, crank the engine until the rotor is aimed at a fixed point on the engine or firewall. Note this position by making a mark (Figure 8).
3. Place the distributor cap back on and note which plug wire the rotor is pointing to. MARK THE SPARK PLUG WIRES and remove the distributor cap.
4. Disconnect the wiring from the distributor.
5. Loosen the distributor hold down clamp and slide the clamp out of the way.
6. Lift the distributor out of the engine. Note that the rotor rotates as you lift the distributor out. This is due to the helical cut gear and should be taken into consideration when installing the new distributor.
7. Install the new O-ring and apply a liberal amount of the supplied lubricant to the distributor gear.
8. Install the distributor making sure that the rotor comes to rest pointing at the fixed mark. If the distributor will not fully seat with the rotor pointing to the marked position, you may need to rotate the oil pump shaft until the rotor lines up and the distributor fully seats.
9. Position and tighten the hold down clamp onto the distributor.
10. Install the distributor cap and spark plug wires one at a time to ensure correct location. A wire retainer is supplied to secure the wires in place. Align the mounting bosses and use the supplied 1.5" self-tapping Phillips screws to hold the retainer in place.

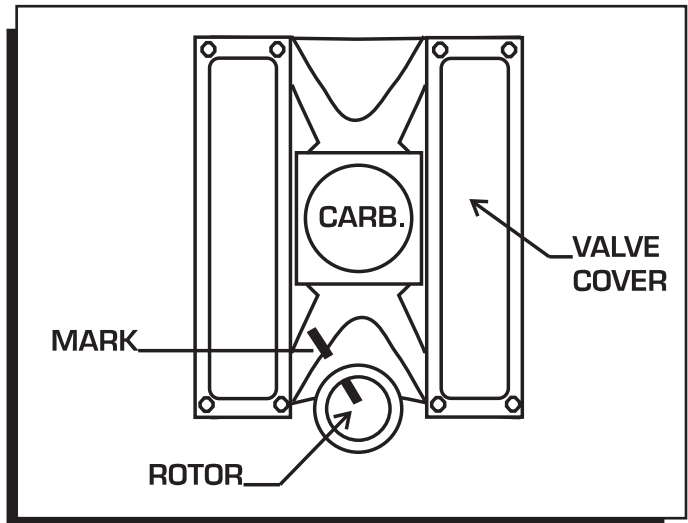

Figure 8 Marking the Rotor Location.

**Installation Option:** This Cap can also be bolted down to an MSD Pro-Billet or Billet Distributor base with the supplied hardware. To accomplish this, the spring clips must be cut off (Figure 9).

**Note:** When the cap is bolted down, the location of the spark plug wires must be changed.

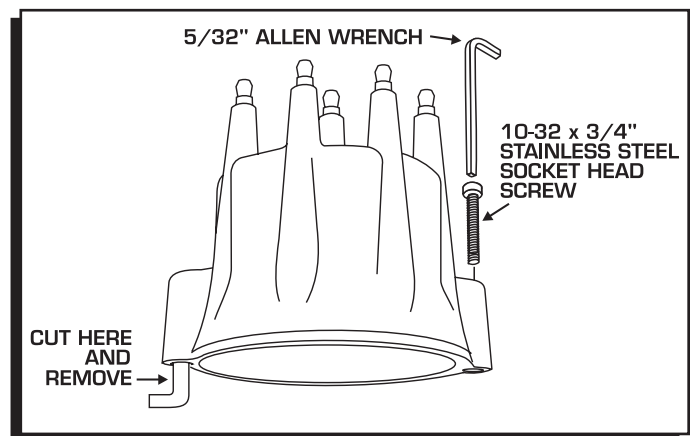

Figure 9 Optional Installation by Bolting Cap Down.

**WARNING:** High voltage is present on the coil terminals. Do not touch the terminals or coil tower when the engine is cranking or running.

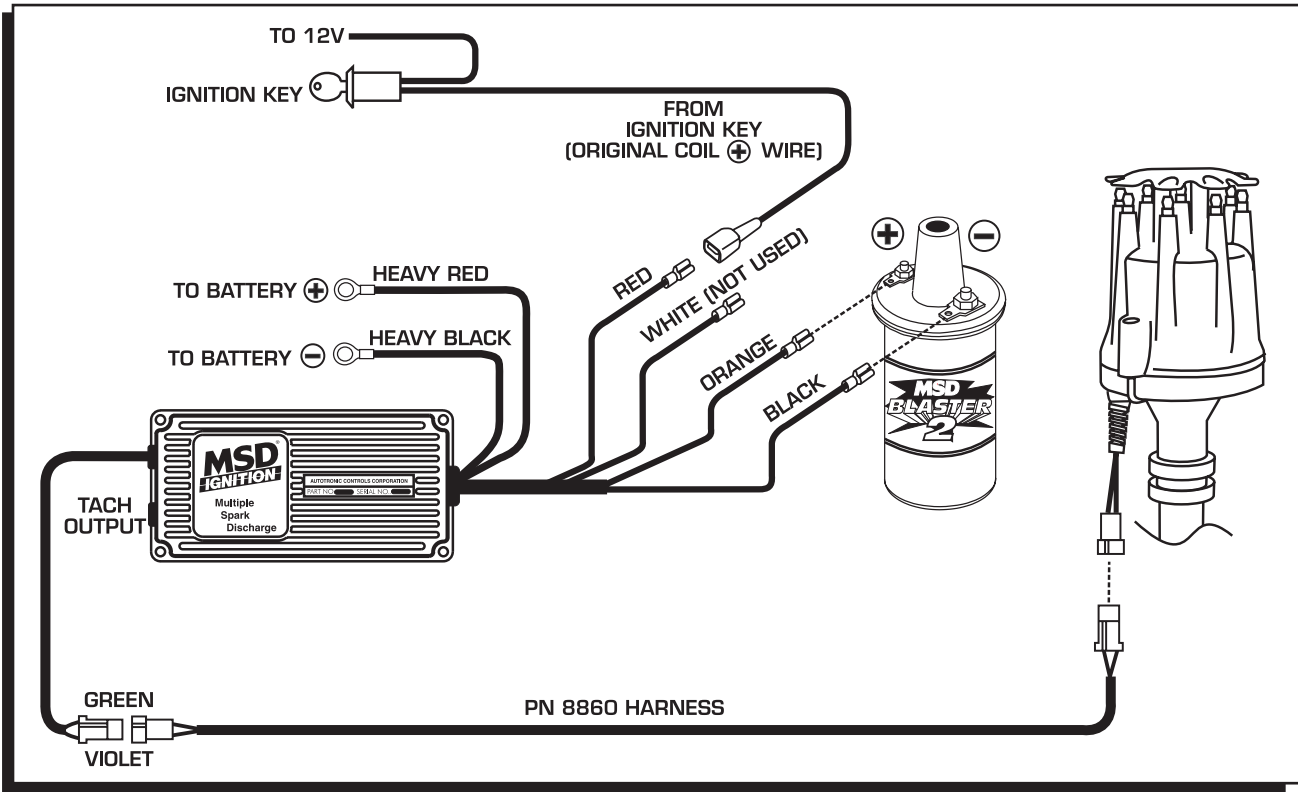

Figure 10 Wiring to an MSD 6-Series Ignition Control.

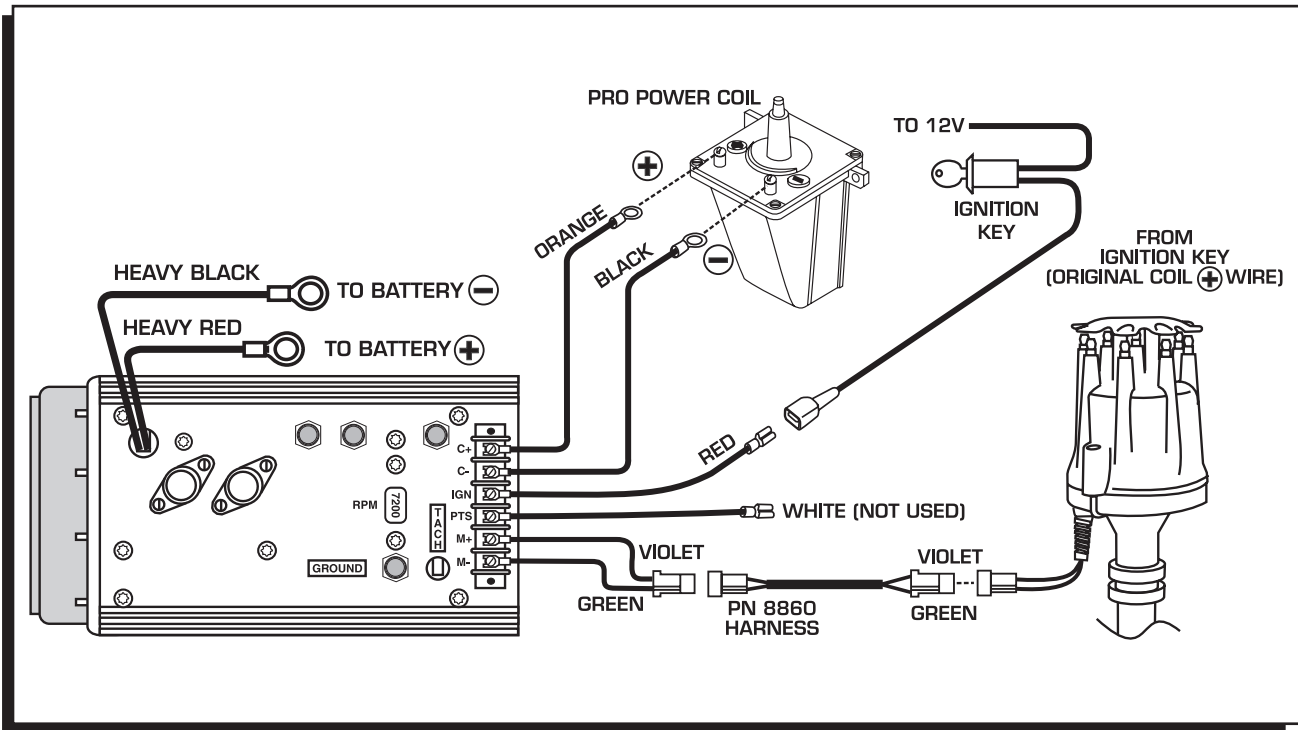

Figure 11 Wiring to an MSD 7-Series Ignition Control.

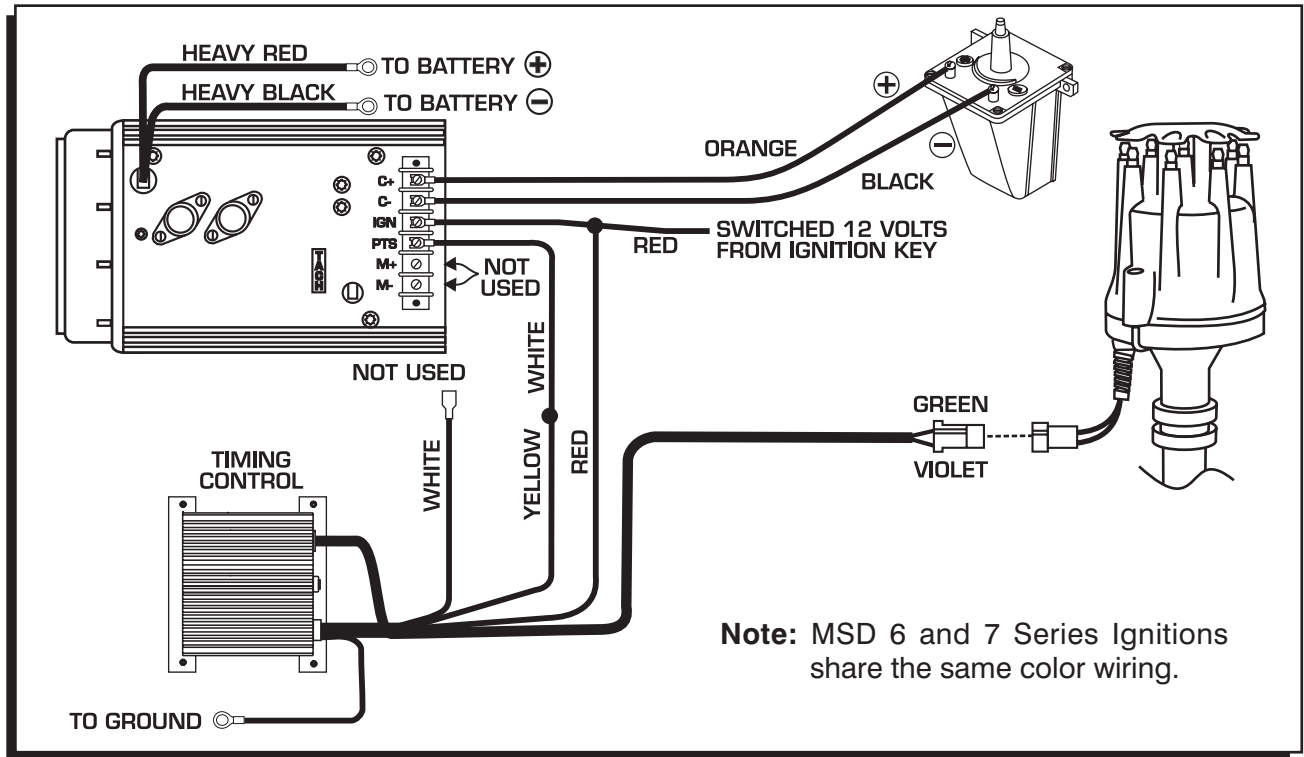

Figure 12 Wiring with an MSD 7-Series Ignition and Timing Control.

### REPLACING THE DISTRIBUTOR GEAR

To replace the distributor gear on the MSD PN 8594 Distributor, the following steps must be followed.

1. Remove the original spiral pin with a punch and press the original gear off the shaft. Press the new gear onto the shaft and line up the holes for the spiral pin. **Note: The holes may not line up.**
2. If the holes line up, measure the distance as shown in the diagram. If the measurement is not correct or the holes do not line up, a new hole must be drilled. If the measurement is within specifications and the holes line up, install a new spiral pin.
3. To drill a new hole, turn the gear on the shaft so the gear hole is approximately 90° to the original shaft hole. Carefully position the gear on the shaft to match the specifications given in the drawing. **Note:** Before measuring, push the shaft in to remove all of the end play.
4. When the gear is in the correct position, drill a 0.125" hole through the distributor shaft. Install a new spiral pin and recheck the measurement.

**Note:** If the measurement is not within specifications after drilling, a slight correction can be made by machining the upper face of the thrust collar. **Do not** remove more than 0.010" or rotor-to-cap interference may result.

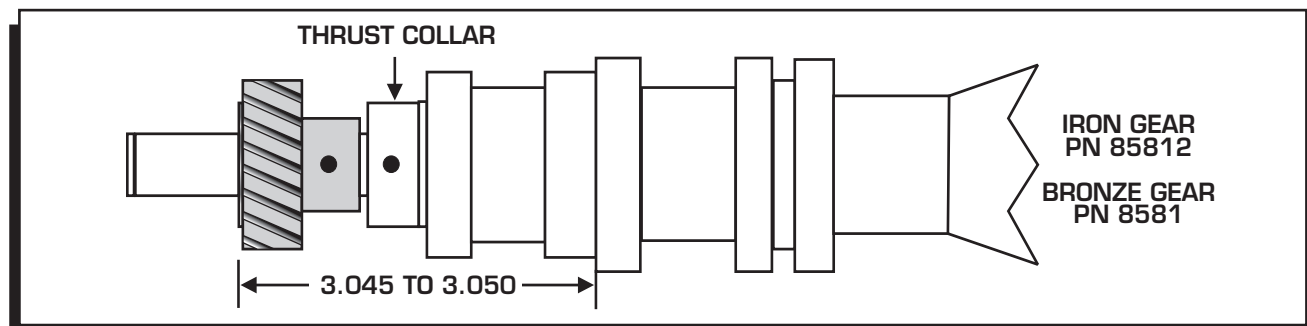

Figure 13 Replacing the Distributor Gear.

