



# INSTALLATION INSTRUCTIONS

MSD Modified Honda Distributor Cap & Rotor  
PN 82903, PN 82913, PN 82923, PN 82933 & PN 82943

Parts Included In This Kit	1 - Rotor
1 - Distributor Cap	1 - Parts Bag
1 - Coil Wire	1 - Mini-Stripper-Crimper

**WARNING:** During installation, disconnect the battery cables. When disconnecting the battery cables, always remove the Negative cable first and install it last.

**Note:** The Modified Cap is designed so that you can remove the stock internal coil, and use a higher output external coil. The stock internal coil **MUST** be removed before the installation of this cap. Failure to do so will cause damage to the MSD cap.

**Note:** Spark plug style, 90° terminals are required with this MSD cap.

## INSTALLATION:

1. Mark the location of each plug wire on the distributor cap, then remove the wires. Remove the stock distributor cap, rotor and dust cover.
2. Locate the coil wires and note their color and location. On the majority of Honda or Acura engines, the Black/Yellow wire is positive. The coil negative wire is generally White/Blue, Blue, Green/Yellow or Green. In some cases, the coil itself is marked negative (-) and positive (+).

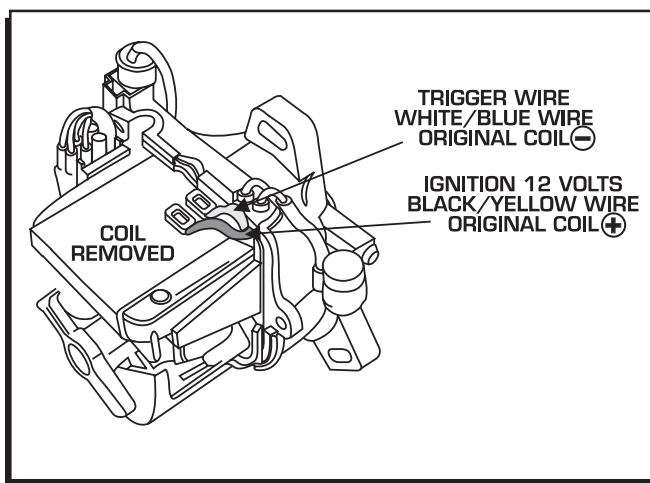

Figure 1 Primary Wiring with the Coil Removed.

**Note:** If you have a question as to the wires' polarity, use a volt-meter and probe each wire with the ignition key turned to the On position. Coil positive will show 10-12 volts.

3. Once you determine the polarity of the coil wires you will need to extend the wires to reach the MSD external coil. Cut the factory terminals off and solder them to 14-gauge wiring. Seal the soldered joint with shrink sleeve or electrical tape.
4. Depending on the model of distributor you have, you may need to drill a hole in the new cap to route the wires out. In some applications the factory rubber seal is thick enough to cut and slide the new wires out.

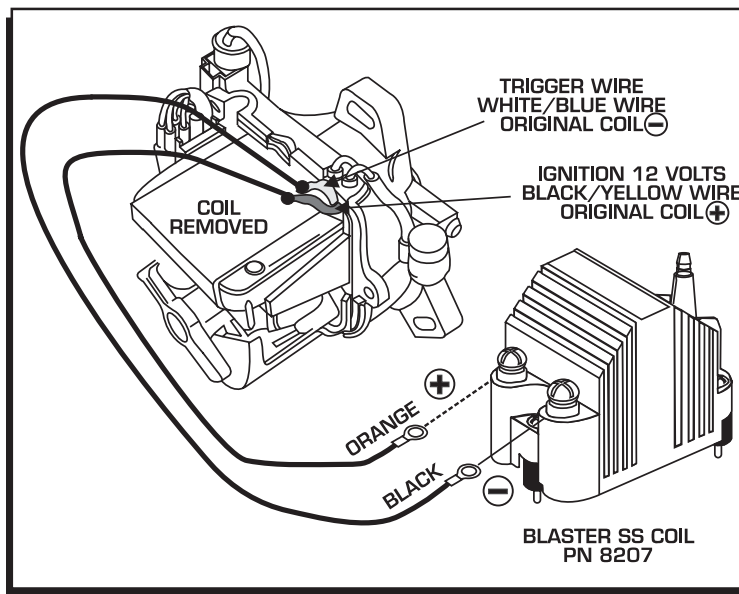

Figure 2 Wiring with a Blaster SS Coil.

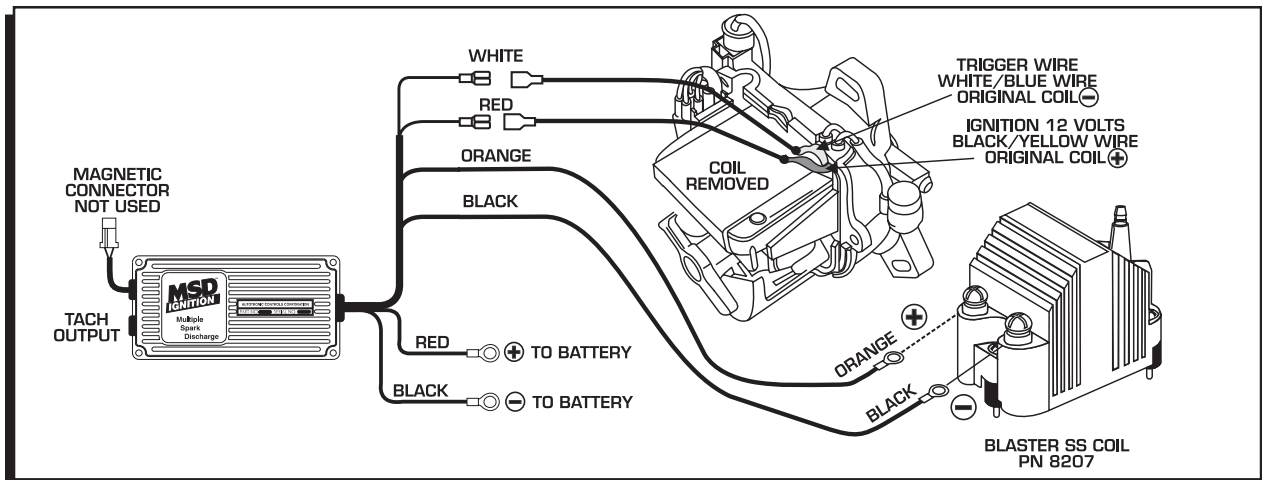

Figure 3 Wiring an MSD SCI Ignition with a Blaster SS Coil.

5. Replace the rotor. Depending on the application, the dust cover may need to be removed or the engine may need to be rotated to access the rotor retaining screw (figure 4). Install the cap and wires.



Figure 4 Replacing the Rotor.

### ASSEMBLING THE COIL WIRE

Once the cap is installed and the coil is wired, you will need to assemble a coil wire. You will need a razor blade and a 4-inch vice.

The Mini-Stripper-Crimper is an all in one spark plug wire stripper and crimp tool. It will work with both MSD 8.5mm Super Conductor and 8mm Heli-Core wires to produce a strong, professional crimp.

### TERMINALS

MSD offers several different terminals with our Universal wire sets. There are two terminal styles used, either a standard style or the Dual Crimp Terminal (Figure 5). The standard design requires stripping more of the wire sleeve because the conductor will be bent under the terminal. The Dual Crimp has specific crimp tabs for the conductor which require needle nose pliers.

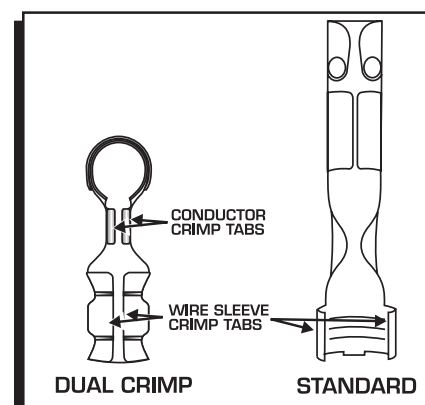

Figure 5 Identifying the Different Style Terminals.

STRIPPING THE WIRE

1. Once you've determined which terminals you are working with, position the wire in the corresponding strip guide. There are two holes; one for the 8mm wire and another for the 8.5mm wire.
2. There are two stripping positions indicated on the stripping slot, depending on the terminal being used. Slide the wire to the correct position and strip the sleeve by holding a razor blade flush with the strip guide and rotate the wire 360° (Figure 6).
3. Remove the wire and twist the cut end of the sleeve off in a counterclockwise direction.

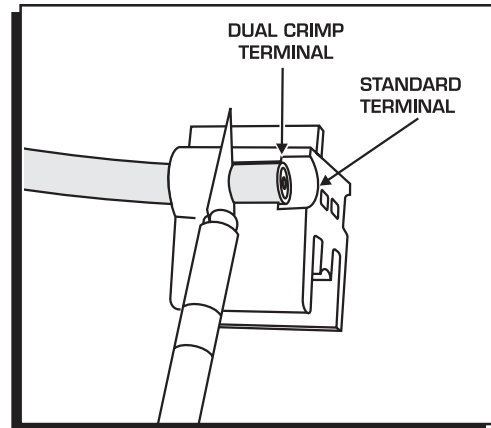

Figure 6 Stripping the Sleeve.

CRIMPING

To achieve the strongest crimp possible, it is required to bend the crimp tabs over about 90° using needle nose pliers (Figure 7). Follow the instructions for the terminal you are using.

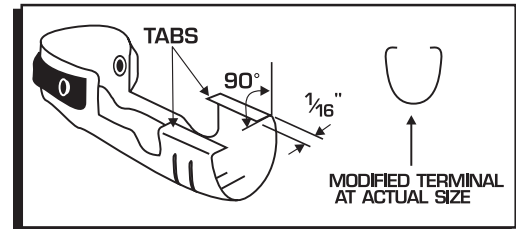

Figure 7 Preparing the Terminals.

STANDARD TERMINALS

1. After stripping the sleeve, fold the conductor back along the wire insulation (Figure 8).
2. Do not allow the conductor to pull tightly against the insulation. A small gap around the conductor should be present before crimping. Slide the wire into the terminal with the conductor positioned so it is in contact with the bottom of the terminal. Position the wire through until the insulation protrudes about 1/8" beyond the crimping tabs.
3. Position the wire and terminal into the "W" groove of the Mini-Stripper Crimper and proceed to Steps 4 - 6.

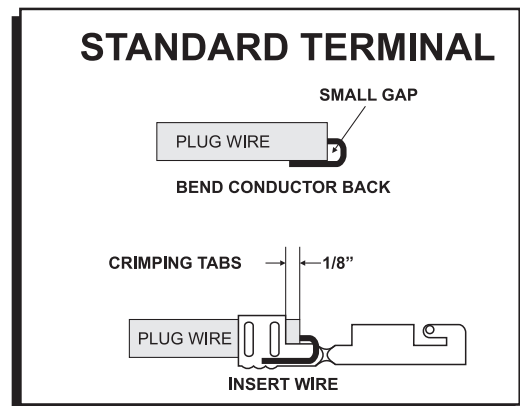

Figure 8 Positioning the Wire in the Terminal.

DUAL CRIMP TERMINALS

1. After stripping the sleeve, position the wire in the terminal so the insulation protrudes about 1/8" beyond the insulation crimp tabs and the conductor extends about 1/8" past the conductor crimp tabs (Figure 9)
2. Position the wire and terminal into the "W" groove of the Mini-Stripper Crimper and follow Steps 3 - 6 to crimp the terminal to the sleeve.

**Note:** It is normal for the conductor to retract into the insulation slightly as the sleeve crimp is made.

3. After the sleeve is crimped, push the conductor between the crimp tabs and use a set of needle nose pliers to crimp them together. DO NOT OVER CRIMP.

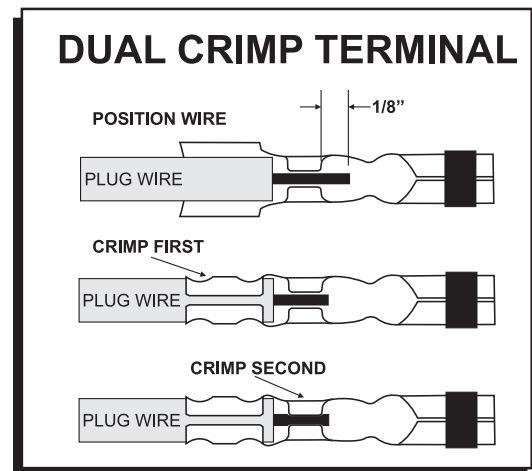

Figure 9 Crimping a Dual Crimp Terminal

# MSD<sup>®</sup> IGNITION INSTALLATION INSTRUCTIONS

- Slide the other part of the Mini-Stripper-Crimper over the wire terminal and lightly press them together (Figure 10).
- Put the assembly into a vise making sure the alignment tabs are on the outside edge of the vise jaws (Figure 10).
- Slowly close the vise making sure the tool and terminal stay properly positioned and aligned. Stop applying pressure when the terminal ends have wrapped securely around the sleeve and grip the wire.

**Note: DO NOT OVER CRIMP!**  
It is possible to tear the sleeve of the wire by excessive pressure on the vise. This will cause a weaker crimp.

- Back off the vise and remove the wire from the Crimper. Gently tug the terminal and inspect the position of the conductor to make sure the crimp is solid and firm.

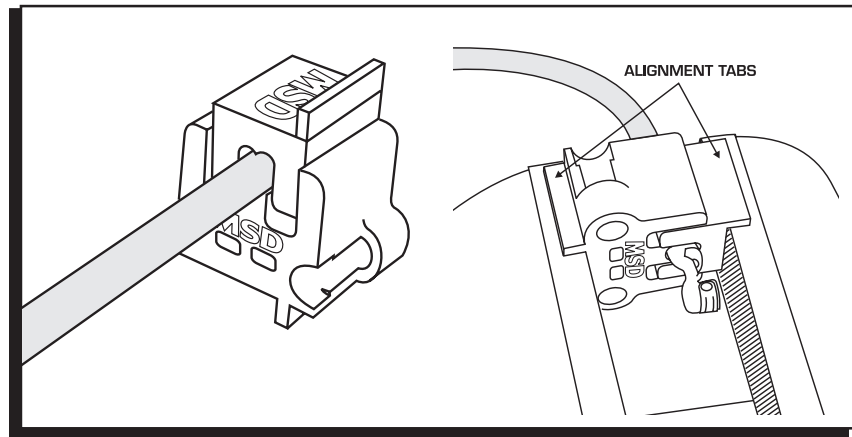

Figure 10 Crimping the Terminal.

## Service

In case of malfunction, this MSD component will be repaired free of charge according to the terms of the warranty. When returning MSD components for service, Proof of Purchase must be supplied for warranty verification. After the warranty period has expired, repair service is charged based on a minimum and maximum charge.

Send the unit prepaid with proof of purchase to the attention of: **Customer Service Department, MSD Ignition, 12120 Esther Lama, Suite 114, El Paso, Texas 79936.**

When returning the unit for repair, leave all wires at the length in which you have them installed. Be sure to include a detailed account of any problems experienced, and what components and accessories are installed on the vehicle.

The repaired unit will be returned as soon as possible after receipt, COD for any charges. (Ground shipping is covered by warranty). All units are returned regular UPS unless otherwise noted. For more information, call the MSD Customer Service Line (915) 855-7123. MSD technicians are available from 8:00 a.m. to 5:00 p.m. Monday - Friday (mountain time).

## Limited Warranty

MSD IGNITION warrants MSD Ignition products to be free from defects in material and workmanship under normal use and if properly installed for a period of one year from date of purchase. If found to be defective as mentioned above, it will be replaced or repaired if returned prepaid along with proof of date of purchase. This shall constitute the sole remedy of the purchaser and the sole liability of MSD Ignition. To the extent permitted by law, the foregoing is exclusive and in lieu of all other warranties or representations whether expressed or implied, including any implied warranty of merchantability or fitness. In no event shall MSD Ignition be liable for special or consequential damages.