



Part Number 30-2340-N
**AEM 4-CH WIDEBAND UEGO CONTROLLER WITH
 NASCAR SPEC ECU CAN CONFIGURATION**

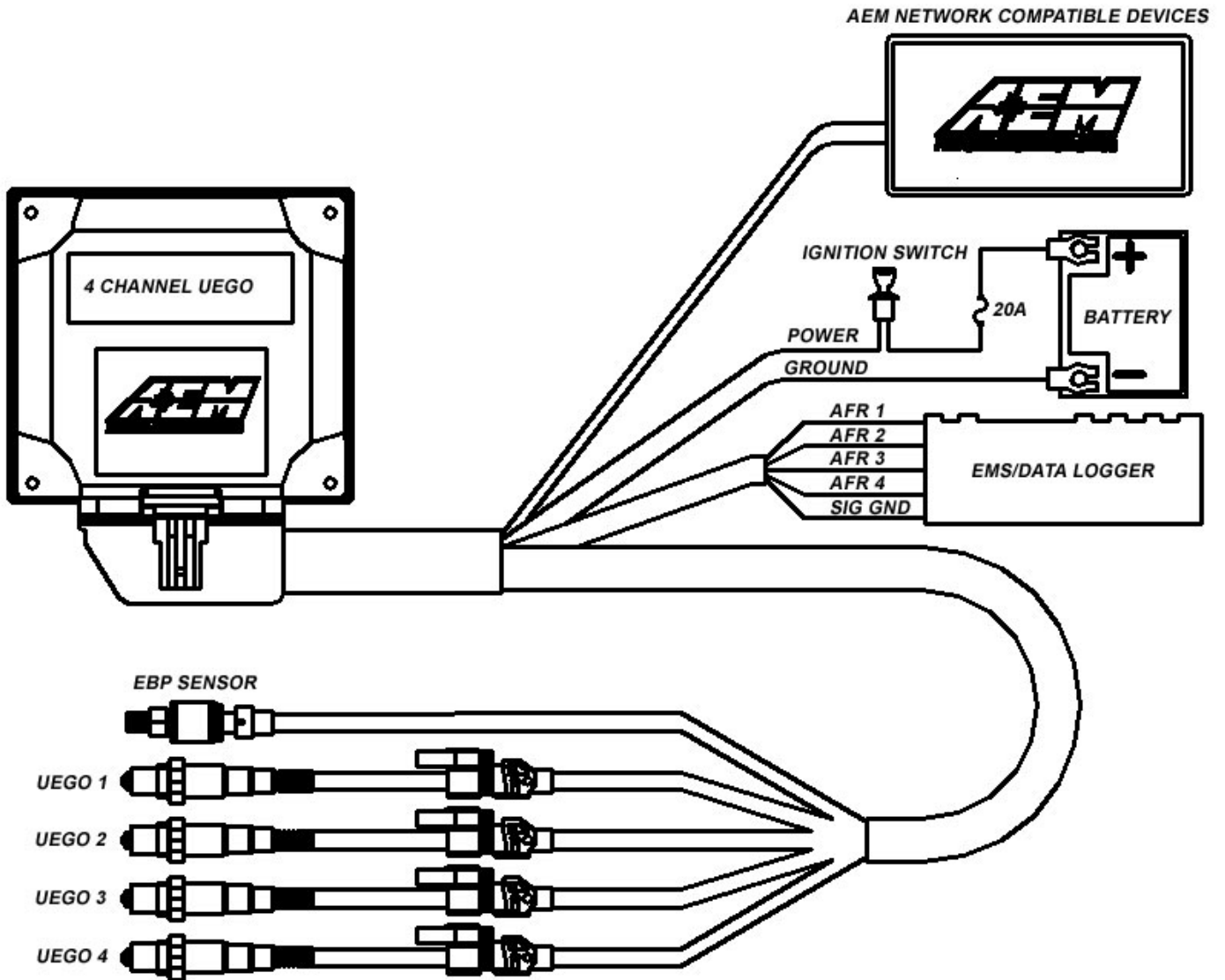

FIGURE 1. WIRING DIAGRAM

AEM 4 CH UEGO Controller Parts

1 x 35-2340	4 CH UEGO Module
1 x 35-2908	Wiring Harness
4 x 1-2059	6-32 Stainless Steel Hex Nut
4 x 1-2047	6-32 x 1 ¼ screw
1 x 10-2340-N	Installation Instructions

INSTALLATION

PROCEDURE OVERVIEW

1. Disconnect the negative battery cable.
2. Find a suitable mounting location for the 4 CH UEGO controller, away from any direct heat or water sources and shielded from the elements.
3. Connect the flying lead analog output wires as shown in Figure 1.
4. Mount the UEGO sensors as shown in figure 2.
5. Plug the UEGO sensor connector on the harness into the mating connector on each UEGO sensor.
6. Install the 30-2064 EBP sensor kit* and connect it as shown in Figure 1.

* Sold Separately

WIRING INSTRUCTIONS

Power

RED - Connect to a switched, fused (20A) 12-volt power source, that is on only when the engine is running.

BLACK – Connect to a clean power ground.

Outputs

WHITE - Connect to Lambda + Input.

BLACK - Connect to sensor ground. Connect to power ground if sensor ground is not available.

MOUNTING INSTRUCTIONS

UEGO Sensor Mounting

A high flow stainless steel weld-in sensor bung is needed for sensor installation (additional sensors & bungs are available 30-2063). The bung is specifically designed so the sensor can provide accurate AFR readings with minimal flow intrusion and survive extreme exhaust gas temperatures. Pick a mounting location(s) that allows for easy access to the sensor(s). The sensor tip must be exposed to exhaust gas in order to give accurate AFR readings. For thin wall tubing, drill a 15/16" hole and weld in the bung. For thick wall tubing/ castings, drill a 1 1/16" hole and weld in the bung. The sensor must be mounted at an angle of at least 10 degrees from horizontal in order to prevent liquids from collecting in the sensor housing. See Figure 2 below. **NOTE: THE OPTIONAL AEM EBP (EXHAUST BACK PRESSURE) KIT (PART # 30-2064) MUST BE USED IF SENSORS ARE MOUNTED PRE-TURBO.**

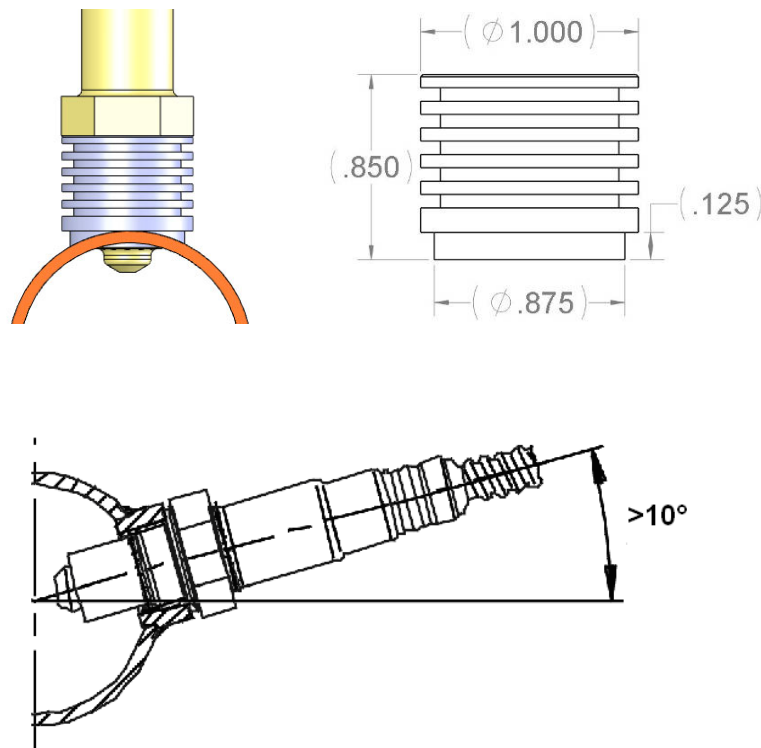

FIGURE 2. Sensor Bung and Sensor Mounting

Controller Mounting

Mount the controller using the supplied 6-32 x 1 ¼ stainless steel screws and nuts. See Figure 3 and Figure 4 for mounting holes and footprint size.

Mounting
Screws



FIGURE 3. Mounting holes

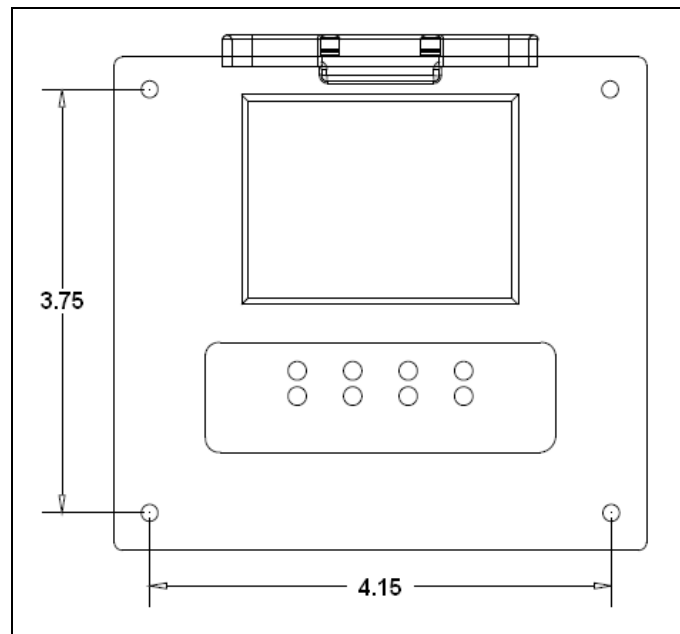

FIGURE 4. Dimensions

OPERATING INSTRUCTIONS

INDICATOR LIGHTS

The AEM 4 CH UEGO controller has eight indicator LEDs, one Status and one Ready LED for each channel (Figure 5). Both Ready and Status LEDs flash during sensor

warm up. Once the UEGO sensor reaches operating temperature, usually within 30 seconds, the Status LED will turn off and the Ready LED will remain on solid. If a UEGO sensor error is detected, analog output will switch to approximately +5V and both LEDs will flash. The Status LED will flash on and off a number of times, followed by a short pause, signifying an error code. The error codes are listed below in Table 1.

# of Flashes	Fault	Corrective Action
1	UEGO sensor heater open	Check sensor cable for broken wires/shorts
2	Virtual Ground (VM) Error	
3	Nernst Cell (UN) Error	
4	Pump current (IP) Error	
5	UEGO sensor heater time out	
6	UEGO sensor heater short	
7	System voltage below 10 volts dc	Check electrical system for good connections and proper function

TABLE 1. Error Codes

When there is no UEGO sensor connected to a particular channel, the Status LED of that channel will remain on solid and the Ready LED will turn off after a few minutes. The remaining channels with UEGO sensors connected will function properly.

When the exhaust back pressure kit (30-2064) is used, the 4 CH UEGO controller will monitor exhaust back pressure. **(NOTE: The 4 CH UEGO controller is designed to work with a specific AEM pressure sensor. Do not use any sensor other than the one included in the Exhaust Back Pressure Kit.)** If a pressure sensor error is detected, the 4 CH UEGO controller turns off all Ready LEDs and flashes Status LEDs, starting with CH1 and ending with CH4. The analog output voltage level for all 4 channels switches to approximately +5V to signify an error.

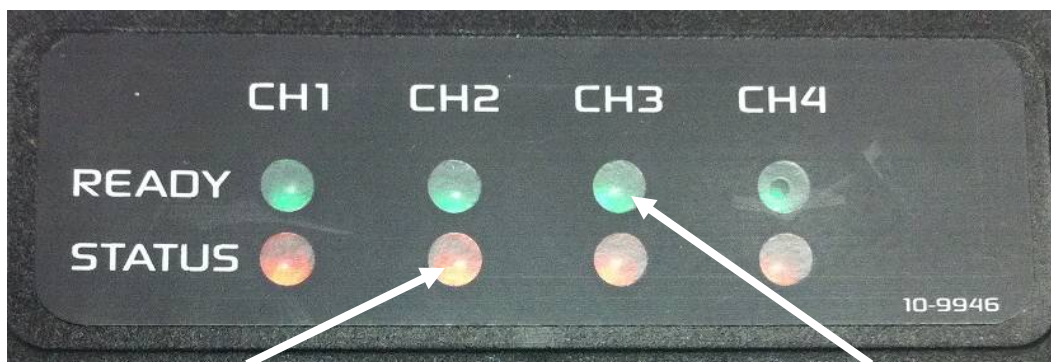

Status Indicator LED

Ready Indicator LED

FIGURE 5. Indicator Lights

BACK PRESSURE COMPENSATION (OPTIONAL)

UEGO sensors are extremely sensitive to pressure. Without an EBP kit (30-2064), UEGO sensors mounted before the turbocharger will give inaccurate AFR readings due to back pressure. When the EBP kit is installed correctly, the 4 CH UEGO controller will output accurate AFR readings. **UNDER NO CIRCUMSTANCES SHOULD UEGO SENSORS BE MOUNTED PRE-TURBO WITHOUT USING THE EBP KIT.**

When using multiple 4 Channel UEGO controllers on twin turbo or dual bank engines, it is recommended that an EBP kit is used for each controller as back pressure levels can vary per bank. When using multiple 4 Channel UEGO controllers on single turbo engines, such as an inline 6, it is possible to share a single EBP source. To share a single EBP source between multiple controllers, the green and black EBP wires for each controller must be tied together as shown in Figures 6 and 7. Use extreme caution when modifying the harness as improper connections may result in inaccurate AFR readings. Be sure to cover all connections with moisture resistant heat shrink or equivalent covering.



Figure 6. EBP sensor connector

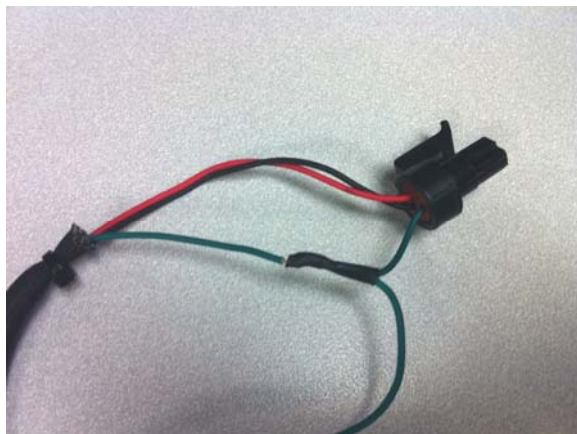

Figure 7. Cut & Spliced wires

UEGO ANALOG OUTPUT

The analog output from the 4 CH UEGO controller is a linear dc voltage signal that varies from **0.5 Vdc at 8.5:1 AFR Gasoline (0.58 Lambda) to 4.5Vdc at 18.0:1 AFR Gasoline (1.22 Lambda)**. The signal is used for sending information to a data logger or an engine management system such as the AEM EMS or F/IC. The transfer function for the output is listed below.

$$\text{AFR Gasoline} = 2.375(V) + 7.3125$$

For example, if the output is 2.0 Vdc, the AFR is 12.06:1

$$2.375 * 2.0 + 7.3125 = 12.06$$

A table showing the analog output voltage and corresponding Air/Fuel ratios for some of the common fuels is shown below in Table 2.

VOLTS	LAMBDA	AFR GAS	AFR METHANOL	AFR E85	AFR ETHANOL
0.50	0.58	8.5	3.7	5.6	5.2
0.71	0.61	9.0	3.9	5.9	5.5
0.92	0.65	9.5	4.1	6.3	5.8
1.13	0.68	10.0	4.4	6.6	6.1
1.34	0.71	10.5	4.6	6.9	6.4
1.55	0.75	11.0	4.8	7.3	6.7
1.76	0.78	11.5	5.0	7.6	7.0
1.97	0.82	12.0	5.2	7.9	7.3
2.18	0.85	12.5	5.4	8.2	7.7
2.39	0.88	13.0	5.7	8.6	8.0
2.61	0.92	13.5	5.9	8.9	8.3
2.82	0.95	14.0	6.1	9.2	8.6
3.03	0.99	14.5	6.3	9.6	8.9
3.11	1.00	14.7	6.4	9.7	9.0
3.24	1.02	15.0	6.5	9.9	9.2
3.45	1.05	15.5	6.7	10.2	9.5
3.66	1.09	16.0	7.0	10.6	9.8
3.87	1.12	16.5	7.2	10.9	10.1
4.08	1.16	17.0	7.4	11.2	10.4
4.29	1.19	17.5	7.6	11.5	10.7
4.50	1.22	18.0	7.8	11.9	11.0

TABLE 2. AFR Values

AEMNet NETWORK

The AEMNet is designed to provide easy installation & communication between compatible AEM devices. The 4 CH UEGO controller outputs Lambda values of all four channels and other useful information via the network. If using a non-AEM device to communicate with the 4 CH UEGO controller, refer to the section " **Connecting To the AEMNet Network Using a non-AEM Device**" below.

4 CH UEGO controller information:

- Lambda values (all 4 channels)
- Error messages (all 4 channels)
 - UEGO sensor Error
 - System low power Error
 - EBP sensor error
- Cylinder Configuration Mode (1 – 7), refer to Table 3.
- Exhaust Back Pressure sensor value in PSIG
- Exhaust Back Pressure sensor status

There are 7 different cylinder numbering combinations available on the AEM network. The different combinations allow for easy installation and data analysis, and allow users to connect up to three 4 Channel UEGO modules on the AEM network. See Table 3 and the figures below for recommended connections on some of the more common engine configurations.

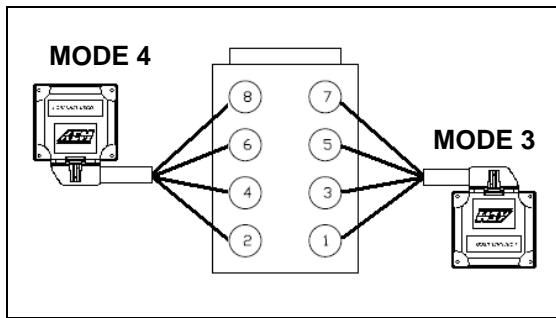

CHEVROLET/ DODGE/ TOYOTA

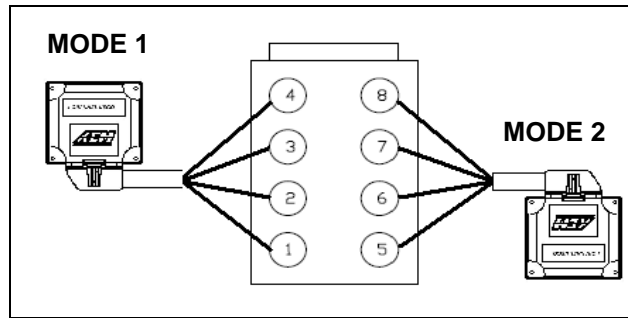

FORD

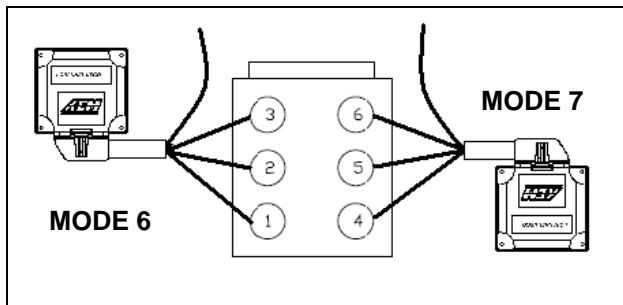

HONDA / ACURA

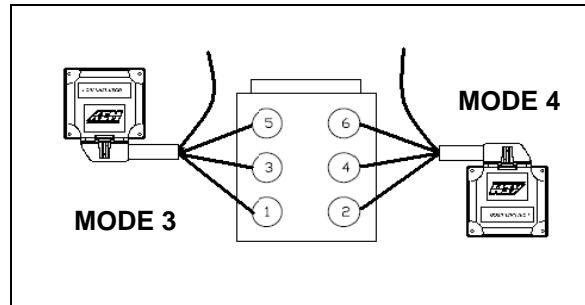

NISSAN / TOYOTA

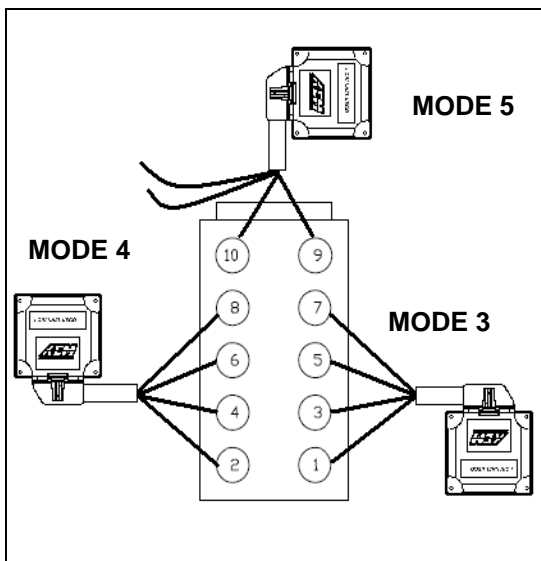

VIPER

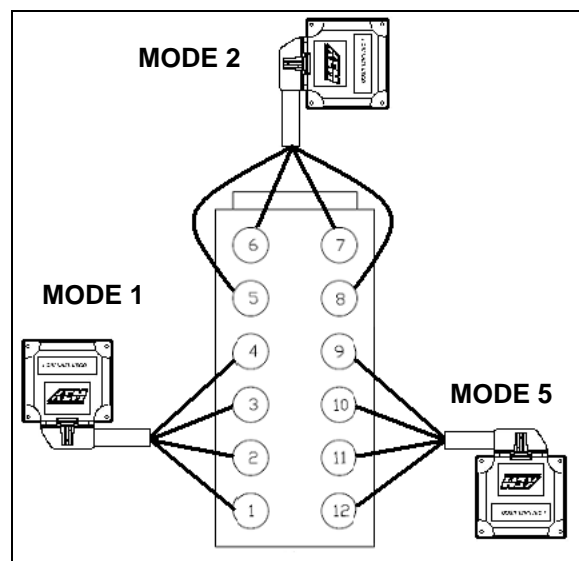

V12

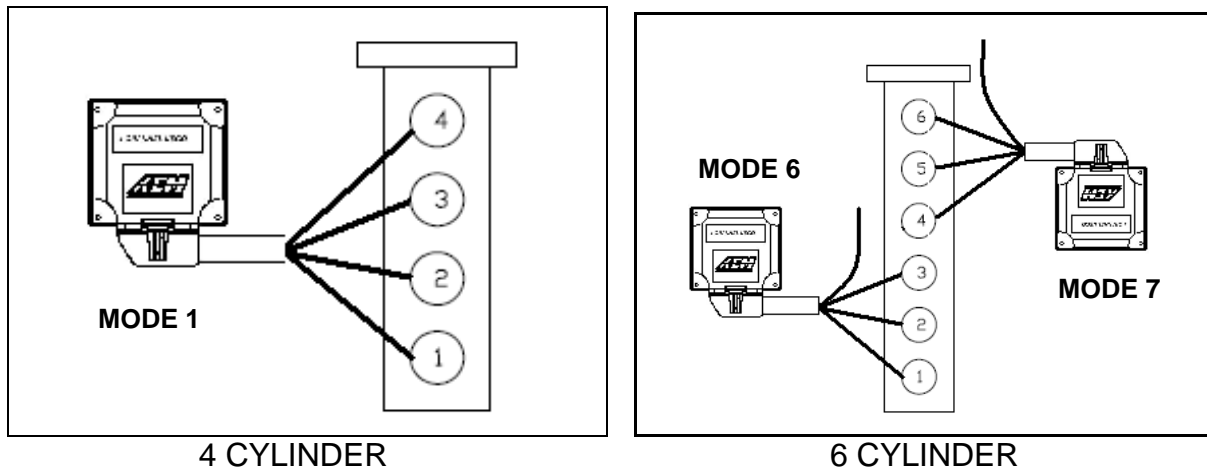

FIGURE 8. 4 CH UEGO controller configuration mode

	MODE 1	MODE 2	MODE 3	MODE 4	MODE 5	MODE 6	MODE 7
UEGO 1	Cylinder1	Cylinder 5	Cylinder 1	Cylinder 2	Cylinder 9	Cylinder 1	Cylinder 4
UEGO 2	Cylinder 2	Cylinder 6	Cylinder 3	Cylinder 4	Cylinder 10	Cylinder 2	Cylinder 5
UEGO 3	Cylinder 3	Cylinder 7	Cylinder 5	Cylinder 6	Cylinder 11	Cylinder 3	Cylinder 6
UEGO 4	Cylinder 4	Cylinder 8	Cylinder 7	Cylinder 8	Cylinder 12	---	---

TABLE 3. UEGO sensor connection

For example, Chevrolet big block engines require two 4 CH UEGO controllers. The first unit connects to cylinders 2, 4, 6 and 8 using MODE 4 (see Table 3). UEGO 1 connects to cylinder 2, UEGO 2 to cylinder 4, UEGO 3 to cylinder 6, and UEGO 4 to cylinder 8. The second unit connects to cylinders 1, 3, 5 and 7 using MODE 3. UEGO 1 connects to cylinder 1, UEGO 2 to cylinder 3, and so on.

Honda / Acura V6 engines also require two 4 CH UEGO controllers. As shown in Figure 8, Mode 6 and 7 from Table 3 are used. UEGO 1, 2, 3 of the first 4 CH UEGO controller connect to cylinders 1, 2 and 3. UEGO 1, 2, 3 of the second unit go to cylinder 4, 5 and 6. Unused channels can be left unconnected.

Cylinder Mode Configuration

NOTE: Only applicable when using AEMnet.

Configuration mode is selected during the power up sequence. By factory default the 4 CH UEGO controller is in MODE 1. There are three wires, CONFIG 1 (pink), CONFIG 2 (purple) and GROUND (yellow) under the sleeve on the wiring harness (Figure 9). To change the mode, first make sure the 4 CH UEGO controller is powered off. Connect CONFIG 1 to GROUND and power the 4 CH UEGO controller on. Tap CONFIG 2 to the GROUND wire. The 4 Channel UEGO controller will jump to the next mode every time the CONFIG 2 wire is tapped to the GROUND wire. The LEDs will illuminate to

show the selected mode. The number of Status/Error LED's illuminated corresponds to the mode selected. When a desired mode is selected, disconnect both CONFIG wires from the GROUND wire. The mode will be saved in the controller and the LEDs of the corresponding mode will blink three times. **When more than one 4 CH UEGO controller is connected to the net, the controllers must be in different modes.** Upon powering up, the number of LEDs corresponding to the mode will blink three times to indicate the mode. For example, if in mode 7, 7 LED's will blink 3 times.

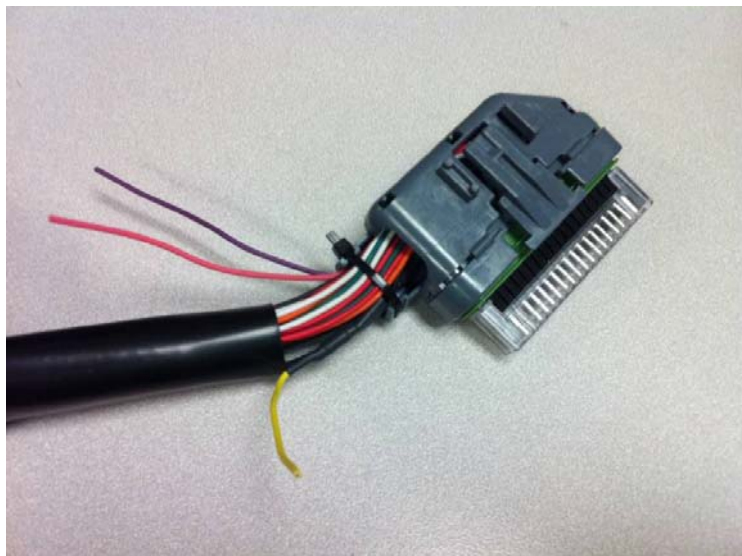

FIGURE 9. Mode Configuration Wires

Connecting to the AEMnet Network

Each 4 CH UEGO controller wiring harness has 2 connectors for accessing the AEMnet (Refer to figure 10), one for accessing the network and the other for an expansion to other devices.



FIGURE 10. AEMnet Connector

To join the AEM network, connect the Deutsch male connector to the female connector of other AEM devices in the network (Figure 11).

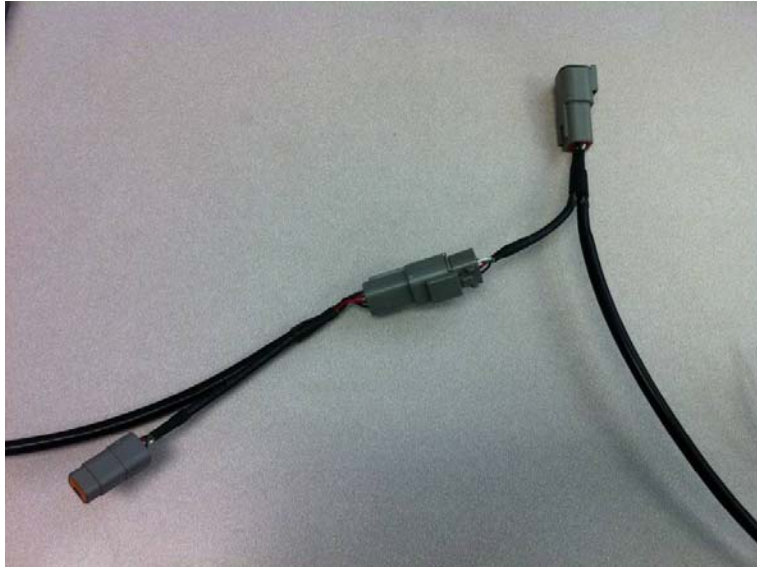

FIGURE 11. AEMnet cable connection

Connecting To The AEMnet Network Using a non-AEM Device with CAN

Each AEMnet connector has 4 pins, CAN+ (PIN1, White), CAN- (PIN2, Green) and two pins for power carry-over (PIN3 and PIN4, Red and Black). NOTE: Pin numbers are located at the back of the connector. Non-AEM devices can connect to the AEMnet by connecting their CAN +/- wires to the CAN +/- wires on the AEM network. The parts for mating connectors are listed below and shown in Figure 12.

- Deutsch DTM04-4P (Receptacle connector)
- Deutsch 1060-20-0122 (Pins)
- Deutsch DTM06-4S (Plug connector)
- Deutsch 1062-20-0122 (Pins)



Figure 12. Connector Assembly

NOTE: the 4 CH UEGO controller has one terminating resistor. If an additional terminating resistor is needed, one must be installed on the other device.

Network Message Structure

The 4 CH UEGO controller transmits two messages through the CAN network. The first message contains Lambda values of all four channels and is transmitted every 10 ms. The second message, transmitted every 40 ms, includes error flags, cylinder configuration mode, EBP sensor readings and status. Messages are transmitted at 1Mbps and use standard format message ID (11 bits). Appendix A shows entire message protocols, including message IDs, number of bytes, data field, etc.

Lambda values are scaled up by 10,000 to retain decimal points. For example, if a value of 9,876 is received as a lambda value from a 4 CH UEGO controller, the actual lambda value is 0.9876. Use the following equation to derive the actual lambda value:

$$\text{Actual Lambda value} = \text{Lambda from a message} / 10,000$$

The back pressure value is scaled up by 100. Use the following equation to derive the actual back pressure value.

$$\text{Actual back pressure value (PSIg)} = \text{pressure from a message} / 100$$

USING THE 4 CH UEGO CONTROLLER WITH AN AEM SERIES 2 EMS (Including EMS - 4)

AEMnet Network

Tuner Setup (Must use 01v22 firmware or newer)

In the AEMTuner EMS software go to Wizards -> Setup Wizard. Under Wizard types, click on Setup: CAN Receive. Choose a configuration and click Apply. There are currently 4 configuration types available: MODE 1 + EBP Sensor, MODE 1 + MODE 2, MODE 4 + MODE 5, and MODE 6 + MODE 7. Once this configuration is completed correctly, the word "Matched" will appear next to the configuration chosen, as shown in Figure 13. Read the notes under Configuration Notes and close the window.

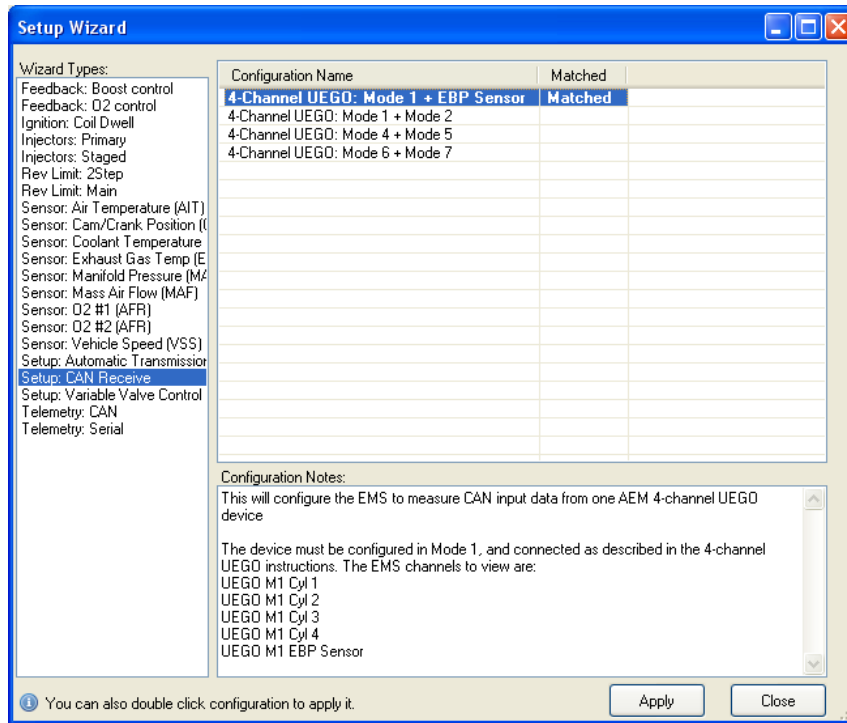

FIGURE 13. Series 2 EMS / EMS – 4 Setup Wizard

Viewing Live Data

Right-click in a blank space in the AEMTuner software and choose Add Channel Display. From the list of available channels, select all the ones associated with the selected configuration mode, as listed in Table 4. Figure 14 shows the Channel display for “Mode 1 + EBP Sensor.”

Configuration Mode	Channels To Be Added
Mode 1 + EBP Sensor	UEGO M1 Cyl 1 UEGO M1 Cyl 2 UEGO M1 Cyl 3 UEGO M1 Cyl 4 UEGO M1 EBP Sensor
Mode 1 + Mode 2	UEGO M1 Cyl 1 UEGO M2 Cyl 1 UEGO M1 Cyl 2 UEGO M2 Cyl 2 UEGO M1 Cyl 3 UEGO M2 Cyl 3 UEGO M1 Cyl 4 UEGO M2 Cyl 4
Mode 4 + Mode 5	UEGO M4 Cyl 1 UEGO M5 Cyl 1 UEGO M4 Cyl 2 UEGO M5 Cyl 2 UEGO M4 Cyl 3 UEGO M5 Cyl 3 UEGO M4 Cyl 4 UEGO M5 Cyl 4
Mode 6 + Mode 7	UEGO M6 Cyl 1 UEGO M7 Cyl 1 UEGO M6 Cyl 2 UEGO M7 Cyl 2 UEGO M6 Cyl 3 UEGO M7 Cyl 3 UEGO M6 Cyl 4 UEGO M7 Cyl 4

TABLE 4. Channel Selection

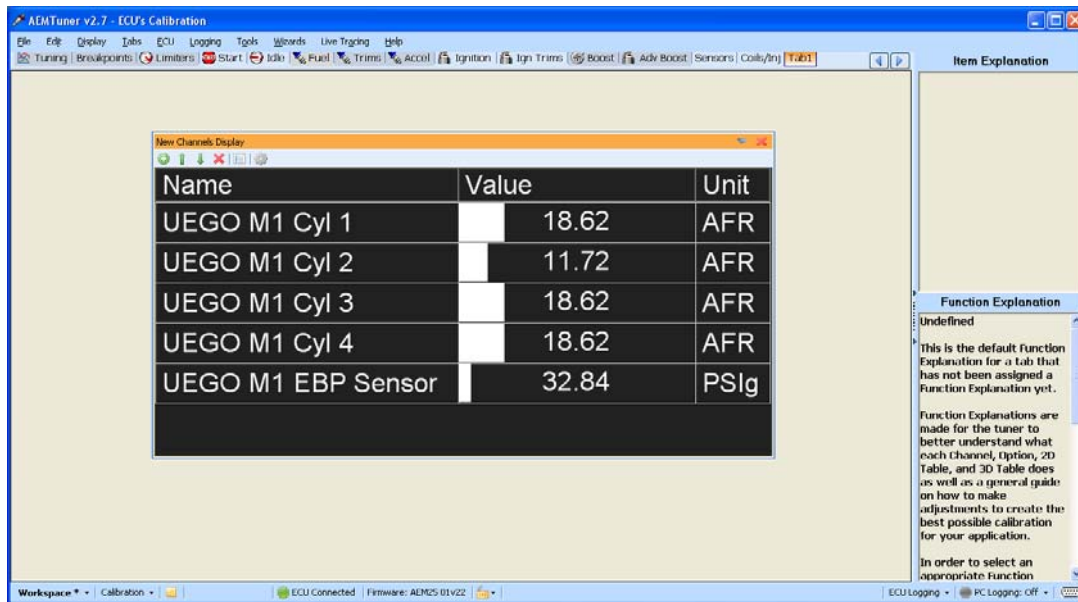

FIGURE 14. Mode 1 + EBP Sensor

Analog Outputs (Refer to EMS Instructions for more information)

Hardware Setup

Connect two WHITE AFR output + wires to O2 #1 and O2 #2 EMS analog input pins. Connect the BLACK Analog Output – wire to the EMS sensor ground.

NOTE: The current version of EMS has only two input pins dedicated to O2 analog inputs. To view the analog outputs from all four channels use spare analog inputs, i.e., EGT1 ~ 4.

Tuner Setup (Must use 01v22 firmware or newer)

With an EMS calibration open in the AEMTuner software, go to Wizards -> Setup Wizard and choose Sensor: O2 #1 (AFR) and Sensor O2 #2 (AFR). Under Configuration Name, choose AEM (4-Channel UEGO PN 30-2340) and click Apply. When the configuration is set, as shown in figure 15, close the wizard.

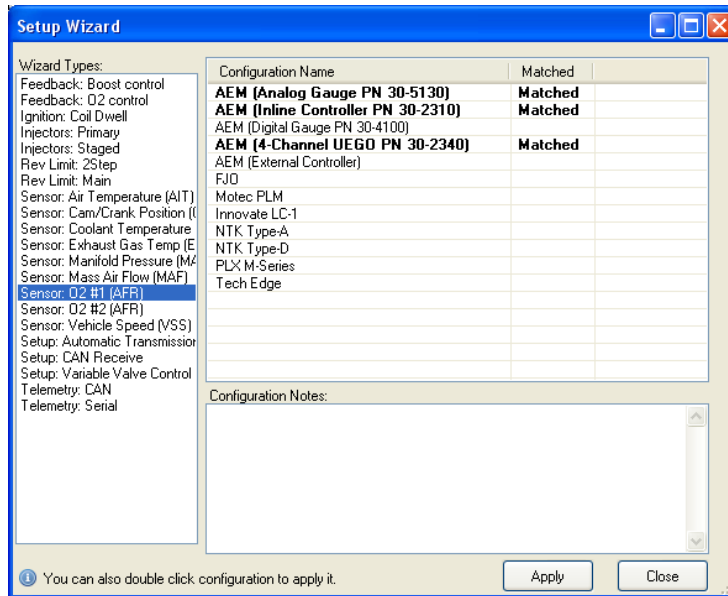

FIGURE 15. Series 2 EMS / EMS – 4 Setup Wizard

Viewing Live Data

Open a new Channels Display in AEMTuner and add O2 #1 and O2 #2 channels. The Channel Display, as shown in figure 16, will show the values in air-to-fuel ratio.

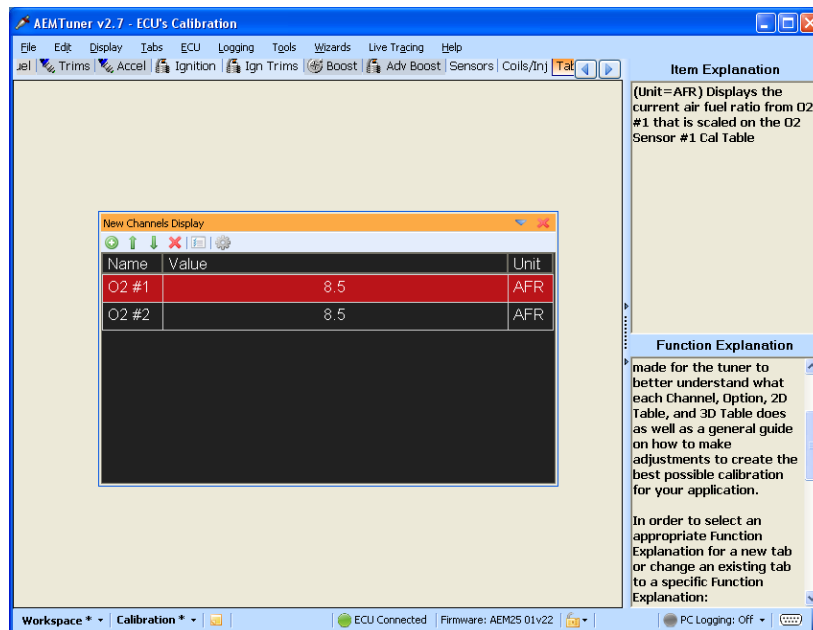

FIGURE 16. O2 #1 and O2 #2

When using spare analog inputs, the values will show in Volts. Use the following equation to convert to air-to-fuel ratio.

$$AFR \text{ Gasoline} = 2.375 \times \text{voltage} + 7.3125$$

CONNECTOR PIN-OUTS

The pin-out for the UEGO sensor connector is shown below in Figure 17.

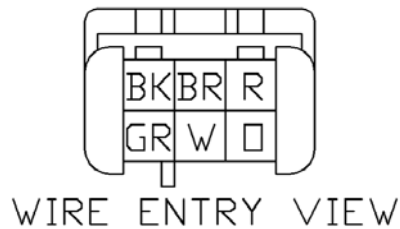

FIGURE 17. UEGO Connector Pin-out

SPECIFICATIONS

4 CH UEGO Controller

Supply Current (nominal, peak)	3.2A, 10.5A peak
Differential Analog Outputs	4
Measuring Range: UEGO	8.5:1 to 18:1 AFR Gasoline, 0.58-1.22 Lambda
UEGO Sensor Accuracy	0.1 AFR
Operating Voltage (nominal)	8.5-15 volts dc
Harness & Connector Temp Limit:	105C

NOTES

If further tuning help is needed be sure to visit the video gallery or performance electronics forum at www.aemelectronics.com for comprehensive instructional videos and information.

The UEGO sensor contains a ceramic module and should not be subject to mechanical or thermal shock or it may be damaged. The sensor is not designed for operation on leaded fuels; doing so will dramatically shorten sensor life. Long term running in the rich region (Lambda < 0.95) will shorten sensor life. High exhaust temperatures (over 850C) will shorten sensor life. Engine oil consumption at a rate greater than 1 quart per 1,000 miles will shorten sensor life. With the UEGO Sensor installed, do not run the engine without power applied to 4 CH UEGO controller.

REPLACEMENT/OPTIONAL UEGO CONTROLLER COMPONENTS

30-2001	UEGO Sensor
35-4008	Stainless Steel UEGO Sensor Bung
30-2063	Sensor Kit with Stainless Bung
30-2064	Exhaust Back Pressure (EBP) Kit

APPENDIX A

CAN MESSAGE PROTOCOL

CAN 2.0b, 11 bit address, 1 Mbit/sec

8 data bytes/message

All multi-byte data packed big endian unless specified (most significant byte transmitted first)

All bits numbered with the LSB = bit0, MSB = bit7

Message ID: 0x0000001F

Source: AEM 4 Channel UEGO set on MODE 1

Rate: 10ms continuous

Byte	Label	Data Type	Scaling	Offset	Range
0	Lambda 1	16 bit unsigned	.0001 Lambda/bit	0	0 to 6.5535 Lambda
1					
2	Lambda 2	16 bit unsigned	.0001 Lambda/bit	0	0 to 6.5535 Lambda
3					
4	Lambda 3	16 bit unsigned	.0001 Lambda/bit	0	0 to 6.5535 Lambda
5					
6	Lambda 4	16 bit unsigned	.0001 Lambda/bit	0	0 to 6.5535 Lambda
7					

Message ID: 0x00000020

Source: AEM 4 Channel UEGO set on MODE 2

Rate: 10ms continuous

Byte	Label	Data Type	Scaling	Offset	Range
0	Lambda 5	16 bit unsigned	.0001 Lambda/bit	0	0 to 6.5535 Lambda
1					
2	Lambda 6	16 bit unsigned	.0001 Lambda/bit	0	0 to 6.5535 Lambda
3					
4	Lambda 7	16 bit unsigned	.0001 Lambda/bit	0	0 to 6.5535 Lambda
5					
6	Lambda 8	16 bit unsigned	.0001 Lambda/bit	0	0 to 6.5535 Lambda
7					

Message ID: 0x00000021

Source: AEM 4 Channel UEGO set on MODE 3

Rate: 10ms continuous

Byte	Label	Data Type	Scaling	Offset	Range
0	Lambda 1	16 bit unsigned	.0001 Lambda/bit	0	0 to 6.5535 Lambda
1					
2	Lambda 3	16 bit unsigned	.0001 Lambda/bit	0	0 to 6.5535 Lambda
3					
4	Lambda 5	16 bit unsigned	.0001 Lambda/bit	0	0 to 6.5535 Lambda
5					
6	Lambda 7	16 bit unsigned	.0001 Lambda/bit	0	0 to 6.5535 Lambda
7					

Message ID: 0x00000022

Source: AEM 4 Channel UEGO set on MODE 4

Rate: 10ms continuous

Byte	Label	Data Type	Scaling	Offset	Range
0	Lambda 2	16 bit unsigned	.0001 Lambda/bit	0	0 to 6.5535 Lambda
1					
2	Lambda 4	16 bit unsigned	.0001 Lambda/bit	0	0 to 6.5535 Lambda
3					
4	Lambda 6	16 bit unsigned	.0001 Lambda/bit	0	0 to 6.5535 Lambda
5					
6	Lambda 8	16 bit unsigned	.0001 Lambda/bit	0	0 to 6.5535 Lambda
7					

Message ID: 0x00000023

Source: AEM 4 Channel UEGO set on MODE 5

Rate: 10ms continuous

Byte	Label	Data Type	Scaling	Offset	Range
0	Lambda 9	16 bit unsigned	.0001 Lambda/bit	0	0 to 6.5535 Lambda
1					
2	Lambda 10	16 bit unsigned	.0001 Lambda/bit	0	0 to 6.5535 Lambda
3					
4	Lambda 11	16 bit unsigned	.0001 Lambda/bit	0	0 to 6.5535 Lambda
5					
6	Lambda 12	16 bit unsigned	.0001 Lambda/bit	0	0 to 6.5535 Lambda
7					

Message ID: 0x00000024

Source: AEM 4 Channel UEGO set on MODE 6

Rate: 10ms continuous

Byte	Label	Data Type	Scaling	Offset	Range
0	Lambda 1	16 bit unsigned	.0001 Lambda/bit	0	0 to 6.5535 Lambda
1					
2	Lambda 2	16 bit unsigned	.0001 Lambda/bit	0	0 to 6.5535 Lambda
3					
4	Lambda 3	16 bit unsigned	.0001 Lambda/bit	0	0 to 6.5535 Lambda
5					
6	---	---	---	---	---
7	---	---	---	---	---

Message ID: 0x00000025

Source: AEM 4 Channel UEGO set on MODE 7

Rate: 10ms continuous

Byte	Label	Data Type	Scaling	Offset	Range
0	Lambda 4	16 bit unsigned	.0001 Lambda/bit	0	0 to 6.5535 Lambda
1					

2	Lambda 5	16 bit unsigned	.0001 Lambda/bit	0	0 to 6.5535 Lambda
3					
4	Lambda 6	16 bit unsigned	.0001 Lambda/bit	0	0 to 6.5535 Lambda
5					
6	---	---	---	---	---
7	---	---	---	---	---

Message ID: 0x000001AF

Source: AEM 4 Channel UEGO set on MODE 1

Rate: 40ms continuous

Byte	Label	Data Type	Scaling	Offset	Range
0 (bit0)	AFR 1 Ready	Boolean	0 = false, 1 = true	0	0/1
0 (bit1)	AFR 1 Heater Open Error	Boolean	0 = false, 1 = true	0	0/1
0 (bit2)	AFR 1 VM Error	Boolean	0 = false, 1 = true	0	0/1
0 (bit3)	AFR 1 UN Error	Boolean	0 = false, 1 = true	0	0/1
0 (bit4)	AFR 1 IP Error	Boolean	0 = false, 1 = true	0	0/1
0 (bit5)	AFR 1 Heater Time-Out Error	Boolean	0 = false, 1 = true	0	0/1
0 (bit6)	AFR 1 Heater Short Error	Boolean	0 = false, 1 = true	0	0/1
0 (bit7)	AFR 1 Overtemp Error	Boolean	0 = false, 1 = true	0	0/1
1 (bit0)	AFR 2 Ready	Boolean	0 = false, 1 = true	0	0/1
1 (bit1)	AFR 2 Heater Open Error	Boolean	0 = false, 1 = true	0	0/1
1 (bit2)	AFR 2 VM Error	Boolean	0 = false, 1 = true	0	0/1
1 (bit3)	AFR 2 UN Error	Boolean	0 = false, 1 = true	0	0/1
1 (bit4)	AFR 2 IP Error	Boolean	0 = false, 1 = true	0	0/1
1 (bit5)	AFR 2 Heater Time-Out Error	Boolean	0 = false, 1 = true	0	0/1
1 (bit6)	AFR 2 Heater Short Error	Boolean	0 = false, 1 = true	0	0/1
1 (bit7)	AFR 2 Overtemp Error	Boolean	0 = false, 1 = true	0	0/1
2 (bit0)	AFR 3 Ready	Boolean	0 = false, 1 = true	0	0/1
2 (bit1)	AFR 3 Heater Open Error	Boolean	0 = false, 1 = true	0	0/1
2 (bit2)	AFR 3 VM Error	Boolean	0 = false, 1 = true	0	0/1
2 (bit3)	AFR 3 UN Error	Boolean	0 = false, 1 = true	0	0/1
2 (bit4)	AFR 3 IP Error	Boolean	0 = false, 1 = true	0	0/1
2 (bit5)	AFR 3 Heater Time-Out Error	Boolean	0 = false, 1 = true	0	0/1
2 (bit6)	AFR 3 Heater Short Error	Boolean	0 = false, 1 = true	0	0/1
2 (bit7)	AFR 3 Overtemp Error	Boolean	0 = false, 1 = true	0	0/1
3 (bit0)	AFR 4 Ready	Boolean	0 = false, 1 = true	0	0/1
3 (bit1)	AFR 4 Heater Open Error	Boolean	0 = false, 1 = true	0	0/1
3 (bit2)	AFR 4 VM Error	Boolean	0 = false, 1 = true	0	0/1
3 (bit3)	AFR 4 UN Error	Boolean	0 = false, 1 = true	0	0/1
3 (bit4)	AFR 4 IP Error	Boolean	0 = false, 1 = true	0	0/1
3 (bit5)	AFR 4 Heater Time-Out Error	Boolean	0 = false, 1 = true	0	0/1
3 (bit6)	AFR 4 Heater Short Error	Boolean	0 = false, 1 = true	0	0/1
3 (bit7)	AFR 4 Overtemp Error	Boolean	0 = false, 1 = true	0	0/1
4 (bit0)	UEGO Low Voltage Error	Boolean	0 = false, 1 = true	0	0/1
4 (bit1)	EBP sensor ready	Boolean	0 = false, 1 = true	0	0/1
4 (bit2)	EBP sensor Error Low Volt	Boolean	0 = false, 1 = true	0	0/1

4 (bit3)	EBP sensor detected	Boolean	0 = false, 1 = true	0	0/1
4 (bit4)	CAN Config Mode	Boolean	0 = false, 1 = true	0	0/1
4 (bit5)	CAN Config Mode	Boolean	0 = false, 1 = true	0	0/1
4 (bit6)	CAN Config Mode	Boolean	0 = false, 1 = true	0	0/1
4 (bit7)	CAN Config Mode	Boolean	0 = false, 1 = true	0	0/1
5 (bit0)	Reserved	Boolean	0 = false, 1 = true	0	0/1
5 (bit1)	Reserved	Boolean	0 = false, 1 = true	0	0/1
5 (bit2)	Reserved	Boolean	0 = false, 1 = true	0	0/1
5 (bit3)	Reserved	Boolean	0 = false, 1 = true	0	0/1
5 (bit4)	Sensor 4 Heating up	Boolean	0 = false, 1 = true	0	0/1
5 (bit5)	Sensor 3 Heating up	Boolean	0 = false, 1 = true	0	0/1
5 (bit6)	Sensor 2 Heating up	Boolean	0 = false, 1 = true	0	0/1
5 (bit7)	Sensor 1 Heating up	Boolean	0 = false, 1 = true	0	0/1
6	Exhaust Pressure 1	16 bit unsigned	.001 psig/bit	0	0 to 655.35 psig
7					

Message ID: 0x000001B0

Source: AEM 4 Channel UEGO set on MODE 2

Rate: 40ms continuous

Byte	Label	Data Type	Scaling	Offset	Range
0 (bit0)	AFR 5 Ready	Boolean	0 = false, 1 = true	0	0/1
0 (bit1)	AFR 5 Heater Open Error	Boolean	0 = false, 1 = true	0	0/1
0 (bit2)	AFR 5 VM Error	Boolean	0 = false, 1 = true	0	0/1
0 (bit3)	AFR 5 UN Error	Boolean	0 = false, 1 = true	0	0/1
0 (bit4)	AFR 5 IP Error	Boolean	0 = false, 1 = true	0	0/1
0 (bit5)	AFR 5 Heater Time-Out Error	Boolean	0 = false, 1 = true	0	0/1
0 (bit6)	AFR 5 Heater Short Error	Boolean	0 = false, 1 = true	0	0/1
0 (bit7)	AFR 5 Overtemp Error	Boolean	0 = false, 1 = true	0	0/1
1 (bit0)	AFR 6 Ready	Boolean	0 = false, 1 = true	0	0/1
1 (bit1)	AFR 6 Heater Open Error	Boolean	0 = false, 1 = true	0	0/1
1 (bit2)	AFR 6 VM Error	Boolean	0 = false, 1 = true	0	0/1
1 (bit3)	AFR 6 UN Error	Boolean	0 = false, 1 = true	0	0/1
1 (bit4)	AFR 6 IP Error	Boolean	0 = false, 1 = true	0	0/1
1 (bit5)	AFR 6 Heater Time-Out Error	Boolean	0 = false, 1 = true	0	0/1
1 (bit6)	AFR 6 Heater Short Error	Boolean	0 = false, 1 = true	0	0/1
1 (bit7)	AFR 6 Overtemp Error	Boolean	0 = false, 1 = true	0	0/1
2 (bit0)	AFR 7 Ready	Boolean	0 = false, 1 = true	0	0/1
2 (bit1)	AFR 7 Heater Open Error	Boolean	0 = false, 1 = true	0	0/1
2 (bit2)	AFR 7 VM Error	Boolean	0 = false, 1 = true	0	0/1
2 (bit3)	AFR 7 UN Error	Boolean	0 = false, 1 = true	0	0/1
2 (bit4)	AFR 7 IP Error	Boolean	0 = false, 1 = true	0	0/1
2 (bit5)	AFR 7 Heater Time-Out Error	Boolean	0 = false, 1 = true	0	0/1
2 (bit6)	AFR 7 Heater Short Error	Boolean	0 = false, 1 = true	0	0/1
2 (bit7)	AFR 7 Overtemp Error	Boolean	0 = false, 1 = true	0	0/1
3 (bit0)	AFR 8 Ready	Boolean	0 = false, 1 = true	0	0/1
3 (bit1)	AFR 8 Heater Open Error	Boolean	0 = false, 1 = true	0	0/1

3 (bit2)	AFR 8 VM Error	Boolean	0 = false, 1 = true	0	0/1
3 (bit3)	AFR 8 UN Error	Boolean	0 = false, 1 = true	0	0/1
3 (bit4)	AFR 8 IP Error	Boolean	0 = false, 1 = true	0	0/1
3 (bit5)	AFR 8 Heater Time-Out Error	Boolean	0 = false, 1 = true	0	0/1
3 (bit6)	AFR 8 Heater Short Error	Boolean	0 = false, 1 = true	0	0/1
3 (bit7)	AFR 8 Overtemp Error	Boolean	0 = false, 1 = true	0	0/1
4 (bit0)	UEGO Low Voltage Error	Boolean	0 = false, 1 = true	0	0/1
4 (bit1)	EBP sensor ready	Boolean	0 = false, 1 = true	0	0/1
4 (bit2)	EBP sensor Error Low Volt	Boolean	0 = false, 1 = true	0	0/1
4 (bit3)	EBP sensor detected	Boolean	0 = false, 1 = true	0	0/1
4 (bit4)	CAN Config Mode	Boolean	0 = false, 1 = true	0	0/1
4 (bit5)	CAN Config Mode	Boolean	0 = false, 1 = true	0	0/1
4 (bit6)	CAN Config Mode	Boolean	0 = false, 1 = true	0	0/1
4 (bit7)	CAN Config Mode	Boolean	0 = false, 1 = true	0	0/1
5 (bit0)	Reserved	Boolean	0 = false, 1 = true	0	0/1
5 (bit1)	Reserved	Boolean	0 = false, 1 = true	0	0/1
5 (bit2)	Reserved	Boolean	0 = false, 1 = true	0	0/1
5 (bit3)	Reserved	Boolean	0 = false, 1 = true	0	0/1
5 (bit4)	Sensor 8 Heating up	Boolean	0 = false, 1 = true	0	0/1
5 (bit5)	Sensor 7 Heating up	Boolean	0 = false, 1 = true	0	0/1
5 (bit6)	Sensor 6 Heating up	Boolean	0 = false, 1 = true	0	0/1
5 (bit7)	Sensor 5 Heating up	Boolean	0 = false, 1 = true	0	0/1
6	Exhaust Pressure 2	16 bit unsigned	.001 psig/bit	0	0 to 655.35 psig
7					

Message ID: 0x000001B1

Source: AEM 4 Channel UEGO set on MODE 3

Rate: 40ms continuous

Byte	Label	Data Type	Scaling	Offset	Range
0 (bit0)	AFR 1 Ready	Boolean	0 = false, 1 = true	0	0/1
0 (bit1)	AFR 1 Heater Open Error	Boolean	0 = false, 1 = true	0	0/1
0 (bit2)	AFR 1 VM Error	Boolean	0 = false, 1 = true	0	0/1
0 (bit3)	AFR 1 UN Error	Boolean	0 = false, 1 = true	0	0/1
0 (bit4)	AFR 1 IP Error	Boolean	0 = false, 1 = true	0	0/1
0 (bit5)	AFR 1 Heater Time-Out Error	Boolean	0 = false, 1 = true	0	0/1
0 (bit6)	AFR 1 Heater Short Error	Boolean	0 = false, 1 = true	0	0/1
0 (bit7)	AFR 1 Overtemp Error	Boolean	0 = false, 1 = true	0	0/1
1 (bit0)	AFR 3 Ready	Boolean	0 = false, 1 = true	0	0/1
1 (bit1)	AFR 3 Heater Open Error	Boolean	0 = false, 1 = true	0	0/1
1 (bit2)	AFR 3 VM Error	Boolean	0 = false, 1 = true	0	0/1
1 (bit3)	AFR 3 UN Error	Boolean	0 = false, 1 = true	0	0/1
1 (bit4)	AFR 3 IP Error	Boolean	0 = false, 1 = true	0	0/1
1 (bit5)	AFR 3 Heater Time-Out Error	Boolean	0 = false, 1 = true	0	0/1
1 (bit6)	AFR 3 Heater Short Error	Boolean	0 = false, 1 = true	0	0/1
1 (bit7)	AFR 3 Overtemp Error	Boolean	0 = false, 1 = true	0	0/1
2 (bit0)	AFR 5 Ready	Boolean	0 = false, 1 = true	0	0/1

2 (bit1)	AFR 5 Heater Open Error	Boolean	0 = false, 1 = true	0	0/1
2 (bit2)	AFR 5 VM Error	Boolean	0 = false, 1 = true	0	0/1
2 (bit3)	AFR 5 UN Error	Boolean	0 = false, 1 = true	0	0/1
2 (bit4)	AFR 5 IP Error	Boolean	0 = false, 1 = true	0	0/1
2 (bit5)	AFR 5 Heater Time-Out Error	Boolean	0 = false, 1 = true	0	0/1
2 (bit6)	AFR 5 Heater Short Error	Boolean	0 = false, 1 = true	0	0/1
2 (bit7)	AFR 5 Overtemp Error	Boolean	0 = false, 1 = true	0	0/1
3 (bit0)	AFR 7 Ready	Boolean	0 = false, 1 = true	0	0/1
3 (bit1)	AFR 7 Heater Open Error	Boolean	0 = false, 1 = true	0	0/1
3 (bit2)	AFR 7 VM Error	Boolean	0 = false, 1 = true	0	0/1
3 (bit3)	AFR 7 UN Error	Boolean	0 = false, 1 = true	0	0/1
3 (bit4)	AFR 7 IP Error	Boolean	0 = false, 1 = true	0	0/1
3 (bit5)	AFR 7 Heater Time-Out Error	Boolean	0 = false, 1 = true	0	0/1
3 (bit6)	AFR 7 Heater Short Error	Boolean	0 = false, 1 = true	0	0/1
3 (bit7)	AFR 7 Overtemp Error	Boolean	0 = false, 1 = true	0	0/1
4 (bit0)	UEGO Low Voltage Error	Boolean	0 = false, 1 = true	0	0/1
4 (bit1)	EBP sensor ready	Boolean	0 = false, 1 = true	0	0/1
4 (bit2)	EBP sensor Error Low Volt	Boolean	0 = false, 1 = true	0	0/1
4 (bit3)	EBP sensor detected	Boolean	0 = false, 1 = true	0	0/1
4 (bit4)	CAN Config Mode	Boolean	0 = false, 1 = true	0	0/1
4 (bit5)	CAN Config Mode	Boolean	0 = false, 1 = true	0	0/1
4 (bit6)	CAN Config Mode	Boolean	0 = false, 1 = true	0	0/1
4 (bit7)	CAN Config Mode	Boolean	0 = false, 1 = true	0	0/1
5 (bit0)	Reserved	Boolean	0 = false, 1 = true	0	0/1
5 (bit1)	Reserved	Boolean	0 = false, 1 = true	0	0/1
5 (bit2)	Reserved	Boolean	0 = false, 1 = true	0	0/1
5 (bit3)	Reserved	Boolean	0 = false, 1 = true	0	0/1
5 (bit4)	Sensor 7 Heating up	Boolean	0 = false, 1 = true	0	0/1
5 (bit5)	Sensor 5 Heating up	Boolean	0 = false, 1 = true	0	0/1
5 (bit6)	Sensor 3 Heating up	Boolean	0 = false, 1 = true	0	0/1
5 (bit7)	Sensor 1 Heating up	Boolean	0 = false, 1 = true	0	0/1
6	Exhaust Pressure 1	16 bit unsigned	.001 psig/bit	0	0 to 655.35 psig
7					

Message ID: 0x000001B2

Source: AEM 4 Channel UEGO set on MODE 4

Rate: 40ms continuous

Byte	Label	Data Type	Scaling	Offset	Range
0 (bit0)	AFR 2 Ready	Boolean	0 = false, 1 = true	0	0/1
0 (bit1)	AFR 2 Heater Open Error	Boolean	0 = false, 1 = true	0	0/1
0 (bit2)	AFR 2 VM Error	Boolean	0 = false, 1 = true	0	0/1
0 (bit3)	AFR 2 UN Error	Boolean	0 = false, 1 = true	0	0/1
0 (bit4)	AFR 2 IP Error	Boolean	0 = false, 1 = true	0	0/1
0 (bit5)	AFR 2 Heater Time-Out Error	Boolean	0 = false, 1 = true	0	0/1
0 (bit6)	AFR 2 Heater Short Error	Boolean	0 = false, 1 = true	0	0/1
0 (bit7)	AFR 2 Overtemp Error	Boolean	0 = false, 1 = true	0	0/1

1 (bit0)	AFR 4 Ready	Boolean	0 = false, 1 = true	0	0/1
1 (bit1)	AFR 4 Heater Open Error	Boolean	0 = false, 1 = true	0	0/1
1 (bit2)	AFR 4 VM Error	Boolean	0 = false, 1 = true	0	0/1
1 (bit3)	AFR 4 UN Error	Boolean	0 = false, 1 = true	0	0/1
1 (bit4)	AFR 4 IP Error	Boolean	0 = false, 1 = true	0	0/1
1 (bit5)	AFR 4 Heater Time-Out Error	Boolean	0 = false, 1 = true	0	0/1
1 (bit6)	AFR 4 Heater Short Error	Boolean	0 = false, 1 = true	0	0/1
1 (bit7)	AFR 4 Overtemp Error	Boolean	0 = false, 1 = true	0	0/1
2 (bit0)	AFR 6 Ready	Boolean	0 = false, 1 = true	0	0/1
2 (bit1)	AFR 6 Heater Open Error	Boolean	0 = false, 1 = true	0	0/1
2 (bit2)	AFR 6 VM Error	Boolean	0 = false, 1 = true	0	0/1
2 (bit3)	AFR 6 UN Error	Boolean	0 = false, 1 = true	0	0/1
2 (bit4)	AFR 6 IP Error	Boolean	0 = false, 1 = true	0	0/1
2 (bit5)	AFR 6 Heater Time-Out Error	Boolean	0 = false, 1 = true	0	0/1
2 (bit6)	AFR 6 Heater Short Error	Boolean	0 = false, 1 = true	0	0/1
2 (bit7)	AFR 6 Overtemp Error	Boolean	0 = false, 1 = true	0	0/1
3 (bit0)	AFR 8 Ready	Boolean	0 = false, 1 = true	0	0/1
3 (bit1)	AFR 8 Heater Open Error	Boolean	0 = false, 1 = true	0	0/1
3 (bit2)	AFR 8 VM Error	Boolean	0 = false, 1 = true	0	0/1
3 (bit3)	AFR 8 UN Error	Boolean	0 = false, 1 = true	0	0/1
3 (bit4)	AFR 8 IP Error	Boolean	0 = false, 1 = true	0	0/1
3 (bit5)	AFR 8 Heater Time-Out Error	Boolean	0 = false, 1 = true	0	0/1
3 (bit6)	AFR 8 Heater Short Error	Boolean	0 = false, 1 = true	0	0/1
3 (bit7)	AFR 8 Overtemp Error	Boolean	0 = false, 1 = true	0	0/1
4 (bit0)	UEGO Low Voltage Error	Boolean	0 = false, 1 = true	0	0/1
4 (bit1)	EBP sensor ready	Boolean	0 = false, 1 = true	0	0/1
4 (bit2)	EBP sensor Error Low Volt	Boolean	0 = false, 1 = true	0	0/1
4 (bit3)	EBP sensor detected	Boolean	0 = false, 1 = true	0	0/1
4 (bit4)	CAN Config Mode	Boolean	0 = false, 1 = true	0	0/1
4 (bit5)	CAN Config Mode	Boolean	0 = false, 1 = true	0	0/1
4 (bit6)	CAN Config Mode	Boolean	0 = false, 1 = true	0	0/1
4 (bit7)	CAN Config Mode	Boolean	0 = false, 1 = true	0	0/1
5 (bit0)	---	---	---	---	---
5 (bit1)	---	---	---	---	---
5 (bit2)	---	---	---	---	---
5 (bit3)	---	---	---	---	---
5 (bit4)	Sensor 8 Heating up	Boolean	0 = false, 1 = true	0	0/1
5 (bit5)	Sensor 6 Heating up	Boolean	0 = false, 1 = true	0	0/1
5 (bit6)	Sensor 4 Heating up	Boolean	0 = false, 1 = true	0	0/1
5 (bit7)	Sensor 2 Heating up	Boolean	0 = false, 1 = true	0	0/1
6	Exhaust Pressure 2	16 bit unsigned	.001 psig/bit	0	0 to 655.35 psig
7					

Message ID: 0x000001B3

Source: AEM 4 Channel UEGO set on MODE 5

Rate: 40ms continuous

Byte	Label	Data Type	Scaling	Offset	Range
0 (bit0)	AFR 9 Ready	Boolean	0 = false, 1 = true	0	0/1
0 (bit1)	AFR 9 Heater Open Error	Boolean	0 = false, 1 = true	0	0/1
0 (bit2)	AFR 9 VM Error	Boolean	0 = false, 1 = true	0	0/1
0 (bit3)	AFR 9 UN Error	Boolean	0 = false, 1 = true	0	0/1
0 (bit4)	AFR 9 IP Error	Boolean	0 = false, 1 = true	0	0/1
0 (bit5)	AFR 9 Heater Time-Out Error	Boolean	0 = false, 1 = true	0	0/1
0 (bit6)	AFR 9 Heater Short Error	Boolean	0 = false, 1 = true	0	0/1
0 (bit7)	AFR 9 Overtemp Error	Boolean	0 = false, 1 = true	0	0/1
1 (bit0)	AFR 10 Ready	Boolean	0 = false, 1 = true	0	0/1
1 (bit1)	AFR 10 Heater Open Error	Boolean	0 = false, 1 = true	0	0/1
1 (bit2)	AFR 10 VM Error	Boolean	0 = false, 1 = true	0	0/1
1 (bit3)	AFR 10 UN Error	Boolean	0 = false, 1 = true	0	0/1
1 (bit4)	AFR 10 IP Error	Boolean	0 = false, 1 = true	0	0/1
1 (bit5)	AFR 10 Heater Time-Out Error	Boolean	0 = false, 1 = true	0	0/1
1 (bit6)	AFR 10 Heater Short Error	Boolean	0 = false, 1 = true	0	0/1
1 (bit7)	AFR 10 Overtemp Error	Boolean	0 = false, 1 = true	0	0/1
2 (bit0)	AFR 11 Ready	Boolean	0 = false, 1 = true	0	0/1
2 (bit1)	AFR 11 Heater Open Error	Boolean	0 = false, 1 = true	0	0/1
2 (bit2)	AFR 11 VM Error	Boolean	0 = false, 1 = true	0	0/1
2 (bit3)	AFR 11 UN Error	Boolean	0 = false, 1 = true	0	0/1
2 (bit4)	AFR 11 IP Error	Boolean	0 = false, 1 = true	0	0/1
2 (bit5)	AFR 11 Heater Time-Out Error	Boolean	0 = false, 1 = true	0	0/1
2 (bit6)	AFR 11 Heater Short Error	Boolean	0 = false, 1 = true	0	0/1
2 (bit7)	AFR 11 Overtemp Error	Boolean	0 = false, 1 = true	0	0/1
3 (bit0)	AFR 12 Ready	Boolean	0 = false, 1 = true	0	0/1
3 (bit1)	AFR 12 Heater Open Error	Boolean	0 = false, 1 = true	0	0/1
3 (bit2)	AFR 12 VM Error	Boolean	0 = false, 1 = true	0	0/1
3 (bit3)	AFR 12 UN Error	Boolean	0 = false, 1 = true	0	0/1
3 (bit4)	AFR 12 IP Error	Boolean	0 = false, 1 = true	0	0/1
3 (bit5)	AFR 12 Heater Time-Out Error	Boolean	0 = false, 1 = true	0	0/1
3 (bit6)	AFR 12 Heater Short Error	Boolean	0 = false, 1 = true	0	0/1
3 (bit7)	AFR 12 Overtemp Error	Boolean	0 = false, 1 = true	0	0/1
4 (bit0)	UEGO Low Voltage Error	Boolean	0 = false, 1 = true	0	0/1
4 (bit1)	EBP sensor ready	Boolean	0 = false, 1 = true	0	0/1
4 (bit2)	EBP sensor Error Low Volt	Boolean	0 = false, 1 = true	0	0/1
4 (bit3)	EBP sensor detected	Boolean	0 = false, 1 = true	0	0/1
4 (bit4)	CAN Config Mode	Boolean	0 = false, 1 = true	0	0/1
4 (bit5)	CAN Config Mode	Boolean	0 = false, 1 = true	0	0/1
4 (bit6)	CAN Config Mode	Boolean	0 = false, 1 = true	0	0/1
4 (bit7)	CAN Config Mode	Boolean	0 = false, 1 = true	0	0/1
5 (bit0)	---	---	---	---	---
5 (bit1)	---	---	---	---	---
5 (bit2)	---	---	---	---	---
5 (bit3)	---	---	---	---	---
5 (bit4)	Sensor 12 Heating up	Boolean	0 = false, 1 = true	0	0/1

5 (bit5)	Sensor 11 Heating up	Boolean	0 = false, 1 = true	0	0/1
5 (bit6)	Sensor 10 Heating up	Boolean	0 = false, 1 = true	0	0/1
5 (bit7)	Sensor 9 Heating up	Boolean	0 = false, 1 = true	0	0/1
6	Exhaust Pressure 2	16 bit unsigned	.001 psig/bit	0	0 to 655.35 psig
7					

Message ID: 0x000001B4

Source: AEM 4 Channel UEGO set on MODE 6

Rate: 40ms continuous

Byte	Label	Data Type	Scaling	Offset	Range
0 (bit0)	AFR 1 Ready	Boolean	0 = false, 1 = true	0	0/1
0 (bit1)	AFR 1 Heater Open Error	Boolean	0 = false, 1 = true	0	0/1
0 (bit2)	AFR 1 VM Error	Boolean	0 = false, 1 = true	0	0/1
0 (bit3)	AFR 1 UN Error	Boolean	0 = false, 1 = true	0	0/1
0 (bit4)	AFR 1 IP Error	Boolean	0 = false, 1 = true	0	0/1
0 (bit5)	AFR 1 Heater Time-Out Error	Boolean	0 = false, 1 = true	0	0/1
0 (bit6)	AFR 1 Heater Short Error	Boolean	0 = false, 1 = true	0	0/1
0 (bit7)	AFR 1 Overtemp Error	Boolean	0 = false, 1 = true	0	0/1
1 (bit0)	AFR 2 Ready	Boolean	0 = false, 1 = true	0	0/1
1 (bit1)	AFR 2 Heater Open Error	Boolean	0 = false, 1 = true	0	0/1
1 (bit2)	AFR 2 VM Error	Boolean	0 = false, 1 = true	0	0/1
1 (bit3)	AFR 2 UN Error	Boolean	0 = false, 1 = true	0	0/1
1 (bit4)	AFR 2 IP Error	Boolean	0 = false, 1 = true	0	0/1
1 (bit5)	AFR 2 Heater Time-Out Error	Boolean	0 = false, 1 = true	0	0/1
1 (bit6)	AFR 2 Heater Short Error	Boolean	0 = false, 1 = true	0	0/1
1 (bit7)	AFR 2 Overtemp Error	Boolean	0 = false, 1 = true	0	0/1
2 (bit0)	AFR 3 Ready	Boolean	0 = false, 1 = true	0	0/1
2 (bit1)	AFR 3 Heater Open Error	Boolean	0 = false, 1 = true	0	0/1
2 (bit2)	AFR 3 VM Error	Boolean	0 = false, 1 = true	0	0/1
2 (bit3)	AFR 3 UN Error	Boolean	0 = false, 1 = true	0	0/1
2 (bit4)	AFR 3 IP Error	Boolean	0 = false, 1 = true	0	0/1
2 (bit5)	AFR 3 Heater Time-Out Error	Boolean	0 = false, 1 = true	0	0/1
2 (bit6)	AFR 3 Heater Short Error	Boolean	0 = false, 1 = true	0	0/1
2 (bit7)	AFR 3 Overtemp Error	Boolean	0 = false, 1 = true	0	0/1
3	---	---	---	---	---
4 (bit0)	UEGO Low Voltage Error	Boolean	0 = false, 1 = true	0	0/1
4 (bit1)	EBP sensor ready	Boolean	0 = false, 1 = true	0	0/1
4 (bit2)	EBP sensor Error Low Volt	Boolean	0 = false, 1 = true	0	0/1
4 (bit3)	EBP sensor detected	Boolean	0 = false, 1 = true	0	0/1
4 (bit4)	CAN Config Mode	Boolean	0 = false, 1 = true	0	0/1
4 (bit5)	CAN Config Mode	Boolean	0 = false, 1 = true	0	0/1
4 (bit6)	CAN Config Mode	Boolean	0 = false, 1 = true	0	0/1
4 (bit7)	CAN Config Mode	Boolean	0 = false, 1 = true	0	0/1
5 (bit0)	---	---	---	---	---
5 (bit1)	---	---	---	---	---
5 (bit2)	---	---	---	---	---

5 (bit3)	---	---	---	---	---
5 (bit4)	---	---	---	---	---
5 (bit5)	Sensor 3 Heating up	Boolean	0 = false, 1 = true	0	0/1
5 (bit6)	Sensor 2 Heating up	Boolean	0 = false, 1 = true	0	0/1
5 (bit7)	Sensor 1 Heating up	Boolean	0 = false, 1 = true	0	0/1
6	Exhaust Pressure 1	16 bit unsigned	.001 psig/bit	0	0 to 655.35 psig
7					

Message ID: 0x000001B5

Source: AEM 4 Channel UEGO set on MODE 7

Rate: 40ms continuous

Byte	Label	Data Type	Scaling	Offset	Range
0 (bit0)	AFR 4 Ready	Boolean	0 = false, 1 = true	0	0/1
0 (bit1)	AFR 4 Heater Open Error	Boolean	0 = false, 1 = true	0	0/1
0 (bit2)	AFR 4 VM Error	Boolean	0 = false, 1 = true	0	0/1
0 (bit3)	AFR 4 UN Error	Boolean	0 = false, 1 = true	0	0/1
0 (bit4)	AFR 4 IP Error	Boolean	0 = false, 1 = true	0	0/1
0 (bit5)	AFR 4 Heater Time-Out Error	Boolean	0 = false, 1 = true	0	0/1
0 (bit6)	AFR 4 Heater Short Error	Boolean	0 = false, 1 = true	0	0/1
0 (bit7)	AFR 4 Overtemp Error	Boolean	0 = false, 1 = true	0	0/1
1 (bit0)	AFR 5 Ready	Boolean	0 = false, 1 = true	0	0/1
1 (bit1)	AFR 5 Heater Open Error	Boolean	0 = false, 1 = true	0	0/1
1 (bit2)	AFR 5 VM Error	Boolean	0 = false, 1 = true	0	0/1
1 (bit3)	AFR 5 UN Error	Boolean	0 = false, 1 = true	0	0/1
1 (bit4)	AFR 5 IP Error	Boolean	0 = false, 1 = true	0	0/1
1 (bit5)	AFR 5 Heater Time-Out Error	Boolean	0 = false, 1 = true	0	0/1
1 (bit6)	AFR 5 Heater Short Error	Boolean	0 = false, 1 = true	0	0/1
1 (bit7)	AFR 5 Overtemp Error	Boolean	0 = false, 1 = true	0	0/1
2 (bit0)	AFR 6 Ready	Boolean	0 = false, 1 = true	0	0/1
2 (bit1)	AFR 6 Heater Open Error	Boolean	0 = false, 1 = true	0	0/1
2 (bit2)	AFR 6 VM Error	Boolean	0 = false, 1 = true	0	0/1
2 (bit3)	AFR 6 UN Error	Boolean	0 = false, 1 = true	0	0/1
2 (bit4)	AFR 6 IP Error	Boolean	0 = false, 1 = true	0	0/1
2 (bit5)	AFR 6 Heater Time-Out Error	Boolean	0 = false, 1 = true	0	0/1
2 (bit6)	AFR 6 Heater Short Error	Boolean	0 = false, 1 = true	0	0/1
2 (bit7)	AFR 6 Overtemp Error	Boolean	0 = false, 1 = true	0	0/1
3	---	---	---	---	---
4 (bit0)	UEGO Low Voltage Error	Boolean	0 = false, 1 = true	0	0/1
4 (bit1)	EBP sensor ready	Boolean	0 = false, 1 = true	0	0/1
4 (bit2)	EBP sensor Error Low Volt	Boolean	0 = false, 1 = true	0	0/1
4 (bit3)	EBP sensor detected	Boolean	0 = false, 1 = true	0	0/1
4 (bit4)	CAN Config Mode	Boolean	0 = false, 1 = true	0	0/1
4 (bit5)	CAN Config Mode	Boolean	0 = false, 1 = true	0	0/1
4 (bit6)	CAN Config Mode	Boolean	0 = false, 1 = true	0	0/1
4 (bit7)	CAN Config Mode	Boolean	0 = false, 1 = true	0	0/1
5 (bit0)	---	---	---	---	---

5 (bit1)	---	---	---	---	---
5 (bit2)	---	---	---	---	---
5 (bit3)	---	---	---	---	---
5 (bit4)	---	---	---	---	---
5 (bit5)	Sensor 6 Heating up	Boolean	0 = false, 1 = true	0	0/1
5 (bit6)	Sensor 5 Heating up	Boolean	0 = false, 1 = true	0	0/1
5 (bit7)	Sensor 4 Heating up	Boolean	0 = false, 1 = true	0	0/1
6	Exhaust Pressure 2	16 bit unsigned	.001 psig/bit	0	0 to 655.35 psig
7					

12 MONTH LIMITED WARRANTY

Advanced Engine Management Inc. warrants to the consumer that all AEM High Performance products will be free from defects in material and workmanship for a period of twelve (12) months from date of the original purchase. Products that fail within this 12-month warranty period will be repaired or replaced at AEM's option, when determined by AEM that the product failed due to defects in material or workmanship. This warranty is limited to the repair or replacement of the AEM part. In no event shall this warranty exceed the original purchase price of the AEM part nor shall AEM be responsible for special, incidental or consequential damages or cost incurred due to the failure of this product. The Bosch LSU 4.2 UEGO sensor has a limited life and is not warranted. Warranty claims to AEM must be transportation prepaid and accompanied with dated proof of purchase. This warranty applies only to the original purchaser of product and is non-transferable. All implied warranties shall be limited in duration to the said 12 month warranty period. Improper use or installation, accident, abuse, unauthorized repairs or alterations voids this warranty. AEM disclaims any liability for consequential damages due to breach of any written or implied warranty on all products manufactured by AEM. Warranty returns will only be accepted by AEM when accompanied by a valid Return Goods Authorization (RGA) number. Product must be received by AEM within 30 days of the date the RGA is issued.

Please note that before AEM can issue an RGA for any product, it is first necessary for the installer or end user to contact the AEM Performance Electronics tech line at 1-800-423-0046 to discuss the problem. Most issues can be resolved over the phone. Under no circumstances should a system be returned or a RGA requested before the above process transpires.

Need additional help? Contact the AEM Performance Electronics tech department at 1-800-423-0046 or tech@aempower.com, or visit the AEM Performance Electronics forum at <http://forum.aempower.com/forum/>