

Instruction Manual



P/N 30-0305 X-SERIES GAUGE EGT 1800F / 1000C



STOP! - READ THIS BEFORE INSTALL OR USE!

WARNING:

THIS INSTALLATION REQUIRES WELDING AND INTEGRATION INTO A VEHICLE'S ELECTRICAL SYSTEM. DAMAGE TO SENSITIVE ELECTRONICS, FIRE, OR EXPLOSION MAY OCCUR IF PROPER PRECAUTION IS NOT TAKEN. IF THERE IS ANY DOUBT, **DO NOT** ATTEMPT THE INSTALLATION AND CONSULT A PROFESSIONAL.

NOTE: IT IS THE RESPONSIBILITY OF THE ENGINE TUNER TO ULTIMATELY CONFIRM THE CALIBRATION USE FOR ANY PARTICULAR ENGINE IS SAFE FOR ITS INTENDED USE. AEM HOLDS NO RESPONSIBILITY FOR ANY ENGINE DAMAGE THAT RESULTS FROM THE MISUSE OF THIS PRODUCT.

The 52mm (2-1/16") AEM X-Series Gauge features a four digit central readout and sweeping 24-color-coded LED display, providing immediate reference to the sensor reading in real-time. A 0-5V analog and an AEMnet (CAN bus) output is included and can be used with data loggers or aftermarket ECUs including the AEM Infinity Engine Management System (EMS).

Features

- 2-1/16" / 52mm outer diameter mounting
- Flashing warn / alarm feature
- Peak recall
- US or metric / SI display modes with reversible faceplate
- Black bezel / "EGT" faceplate supplied; Silver / white available as optional purchase
- Locking connectors
- Supports vehicle / system voltages up to 16V
- Auto-dimming display
- 0-5V analog output
- AEMnet (CAN bus) output

KIT CONTENTS	
PN	Description
10-0305	INST, X-SERIES EGT GAUGE 0 TO 1800F / 0 TO 1000C
35-0305	GAUGE ASSY, INST, X-SERIES EGT GAUGE 0 TO 1800F / 0 TO 1000C
35-4302	RED INSULATED BUTT CONNECTORS (6)
35-8618	NUT, KNURLED, M4x0.7 (2)
35-8614	BRACKET, X-SERIES GAUGE
35-3439	CABLE, X-SERIES GAUGE PWR/IO RTD
35-8617	RUBBER BAND, X-SERIES GAUGE
35-2054	SENSOR, TEMPERATURE RTD
35-2055	BUNG, EGT EXTERNAL THREAD
WM-2S	WEDGE LOCK, 2 PIN PLUG
1062-20-0122	SOCKET, SIZE 20 (2)
DTM06-2S	PLUG, 2 PIN

***OPTIONAL * ACCESSORIES**

PN	Description
30-0305-ACC	BEZEL, X-SERIES GAUGE SILVER FACEPLATE, EGT 1800F WHITE

Wiring Installation Diagram

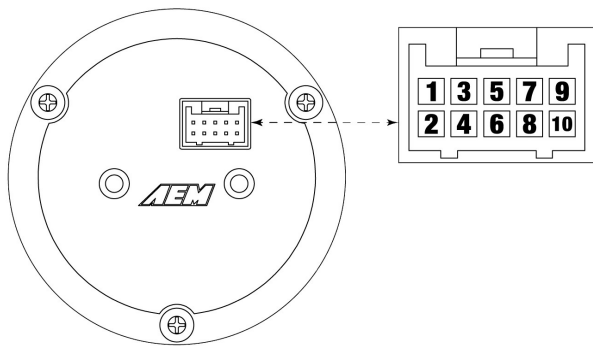
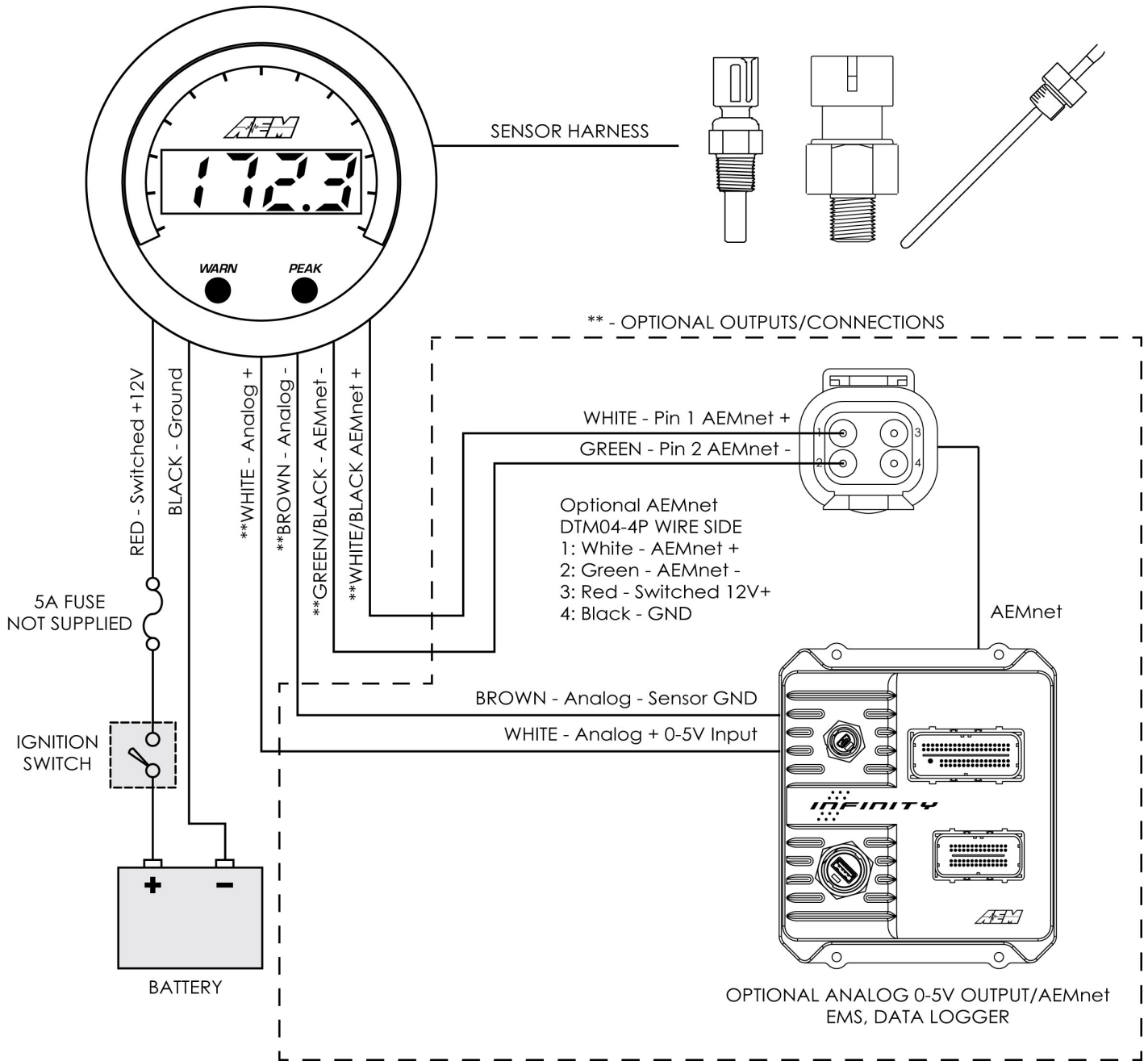

A

Connector A - Power / IO

Pin	Color	Description
1	RED	Switched 12V Power (5A Fuse)
2	BLACK	Power Ground
3	GREEN/BLACK	AEMnet- / CANL
4	WHITE/BLACK	AEMnet+ / CANH
5 - 6	NC	NC
7	GREEN	Sensor Signal Input
8	BLACK	Sensor Ground
9	WHITE	0-5V Analog Output Positive+
10	BROWN	0-5V Analog Output Negative-

Operation

The inner numeric LEDs and outer ring LEDs display the currently measured sensor reading; the inner numeric LEDs will flash when the sensor reading exceeds the (configurable) warn/alarm threshold value. WARN and PEAK buttons are located on the face of the gauge and are used to perform the following functions.

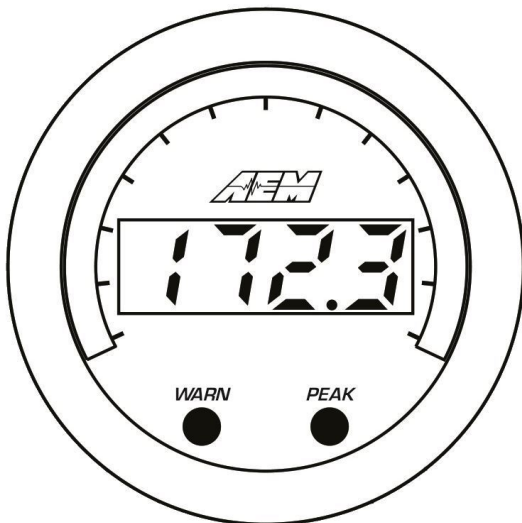

Change display units US / SI (metric)

- § The gauge should be in its normal display mode, showing the current sensor reading
- § Depress and hold the WARN button for three seconds until US or SI appears
- § Press the WARN button to toggle between US or SI (metric) modes

US

English / US units mode

SI

Metric / SI units mode

- § The gauge will return to normal display mode a few seconds after the last button press
- § Note the faceplate is a reversible two-sided design with an alternate scaling on the back
- § Reference the Faceplate/Bezel Installation section in this manual for instruction on how to reverse the faceplate

Display or adjust warn/alarm threshold

- § Press the WARN button; the warn/alarm threshold will be displayed and the outer LEDs will flash
 - § Use either the WARN or PEAK buttons to decrement or increment the threshold value
 - § Depress and hold both the WARN and PEAK buttons until LESS or GrTr appears
 - § Press the WARN button to toggle between LESS and GrTr modes
- LESS** Warn/alarm activated when sensor reading is less than threshold value
- GrTr** Warn/alarm activated when sensor reading is greater than threshold value
- § The gauge will return to normal display mode a few seconds after the last button press

Display or clear stored peak value

- § Press the PEAK button; the peak (highest) sensor reading will be displayed and the outer LEDs will flash
 - § The peak value will be retained across power cycles
 - § While the peak value is being displayed, depress and hold the PEAK button for three seconds until "CLR" appears to clear the peak value
- CLR** Will be displayed to confirm the peak value has been reset
- § The gauge will return to normal display mode shortly after the last button press

Sensor Installation

- § Secure wiring to vehicle with wire ties paying special attention to the sensor harness routing beneath the vehicle and/or in the engine compartment.
- § Take care when routing the sensor harness near hot exhaust components, use strain reliefs and wire coverings as appropriate.
- § Use a 5A inline fuse on the switched 12V power supply line (Pin 1 - Power/IO).

Thermocouple Mounting

The thermocouple included in the kit comes with a stainless steel compression style mounting adapter. The mounting adapter consists of three pieces: compression nut, ferrule sleeve, threaded body. The threaded body has 1/8" NPT male threads. To install the sensor, the threaded body can either be threaded into a hole with mating 1/8" NPT threads, or welded to the pipe/manifold. Remove the compression nut, ferrule sleeve, and thermocouple from the threaded body. For a welded installation, drill a 13/32" hole and weld the threaded body, being careful not to cause any distortion. For a threaded installation, either thread the body into an existing hole with 1/8" NPT threads or drill a hole using an "R" size drill bit and cut the threads using a 1/8" NPT tap. With the compression nut and ferrule sleeve on the thermocouple, insert the

thermocouple into the threaded body so the tip of the thermocouple is near the center of the pipe/manifold and tighten the compression nut to the threaded body.

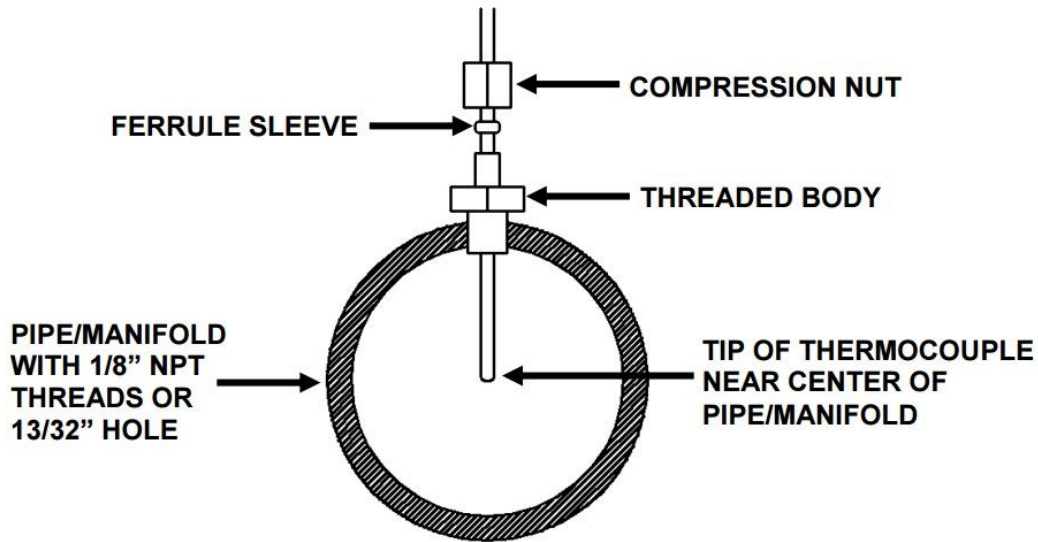

Connecting the Thermocouple

Slide the supplied heat shrink onto the sensor cable. Connect the RED wire from the thermocouple to the RED wire on the harness and the YELLOW wire from the thermocouple to the YELLOW wire on the harness using the supplied 4-40 screws and hex nuts. Make sure the connections are not touching. Center the heat shrink over the connections and apply mild heat to the heat shrink until it shrinks over the connections.

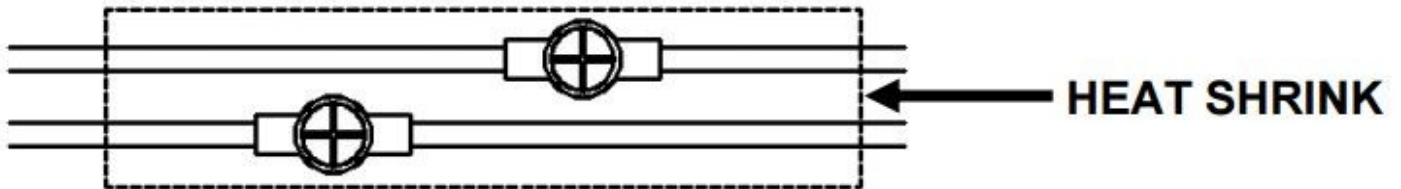

Faceplate / Bezel Installation

The gauge kit is supplied assembled with a black faceplate and black bezel. An accessory kit is available (for purchase through AEM dealers) which includes an optional silver bezel and white faceplate. Please reference the Optional Accessories section earlier in the document for the appropriate part numbers. Contact your dealer or visit www.aemelectronics.com for more information.

The faceplate is reversible, displaying alternative scalings on either side. Reference the Operation section of this manual for details on how to switch the display mode when reversing the faceplate. Disassembly is required to change the faceplate, flip/reverse the faceplate, or change the bezel of the gauge. The following diagram will provide familiarization with the major components of the gauge prior to beginning the procedure.

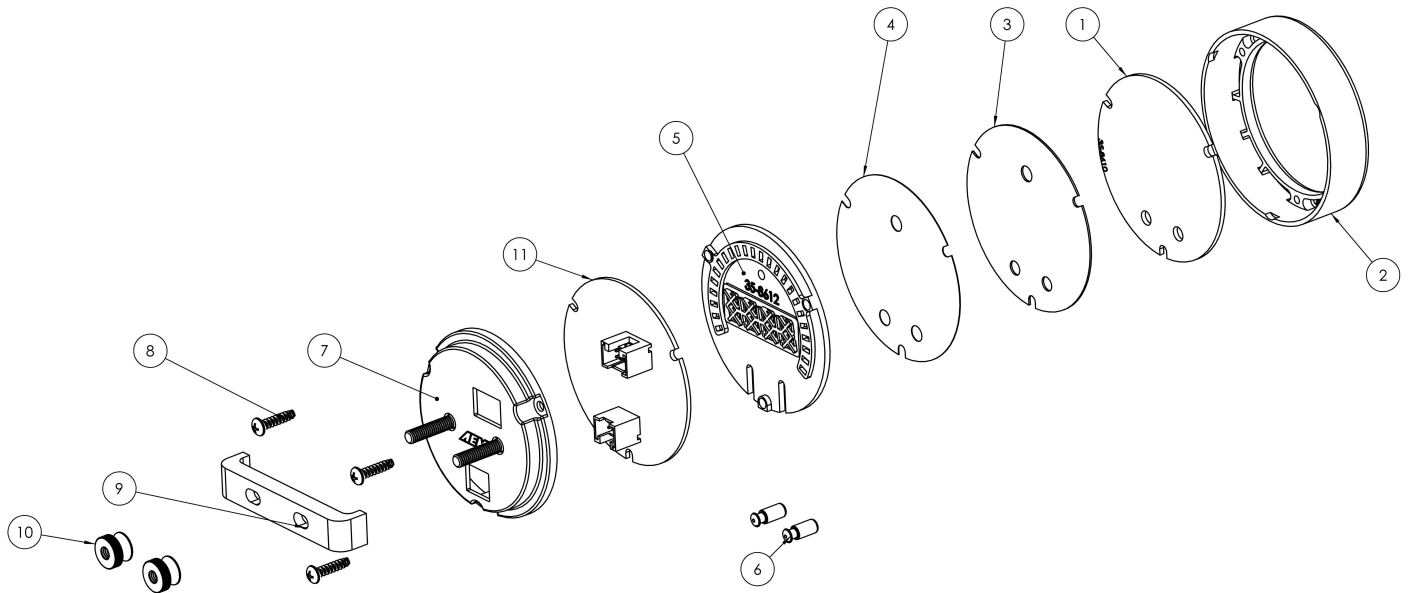

Item	Qty	Description
1	1	Lens
2	1	Bezel
3	1	Faceplate
4	1	Diffuser
5	1	Light Guide
6	2	Button
7	2	Mounting Stud (M4 x 0.7)
8	3	Assembly Screw
9	1	Mounting Bracket
10	2	Brass Thumb Screw (M4 x 0.7)
11	1	Printed Circuit Board (PCB)

Gauge Disassembly

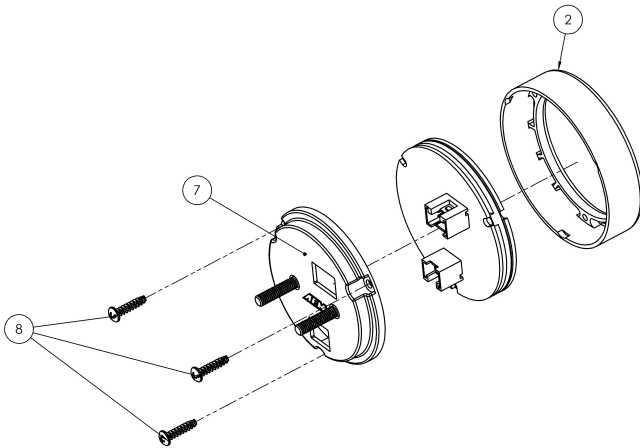

STEP 1 - Remove the three assembly screws (8) using a #1 Phillips head screwdriver. Separate the bezel (2) and cup (7) from the rest of the assembly. If you have purchased the optional accessory kit, the silver bezel may be replaced for the existing bezel at this time

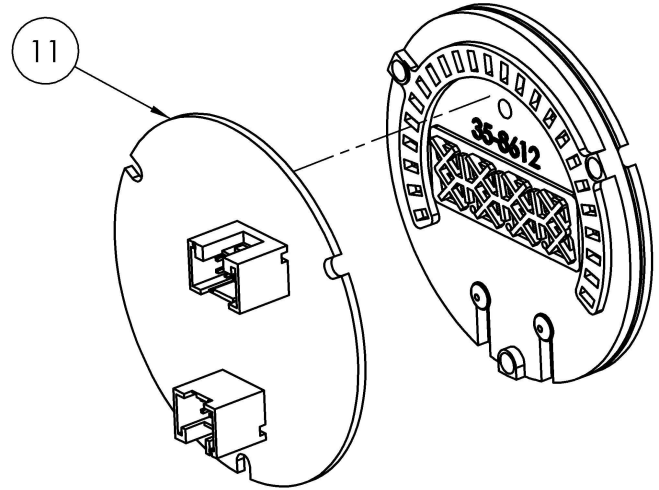

STEP 2 - Separate the PCB (11) from the remaining components

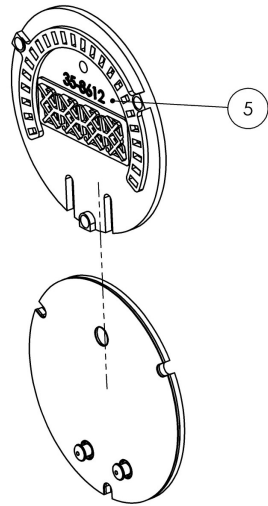

STEP 3 - Slide the light guide (5) upward to remove it, the buttons may fall out at this time - take care not to lose them

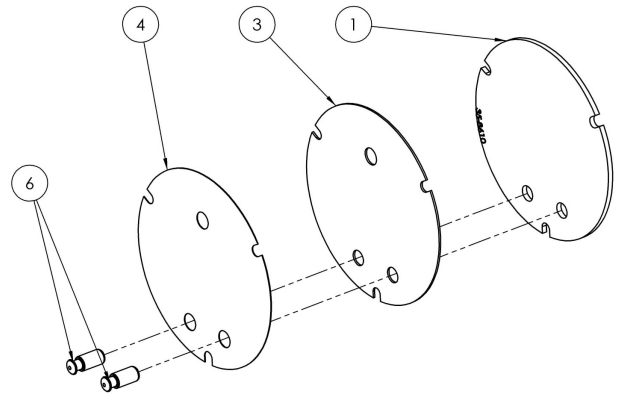

STEP 4 - As you separate the remaining components, diffuser (4), faceplate (3), lens (1), note the order in which they were assembled. The faceplate (3) may now be reversed to display an alternate scaling or replaced for a different color as included in the optional accessory kit

Gauge Assembly

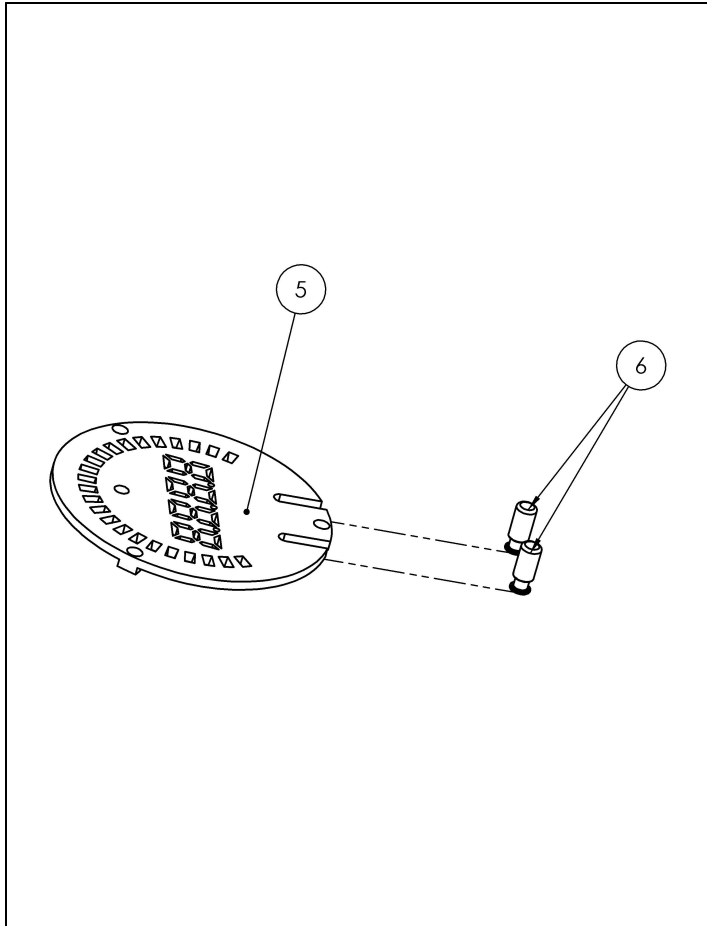

STEP 1 - Place the light guide (5) on a flat surface (black side up) and slide the buttons (6) into the slots

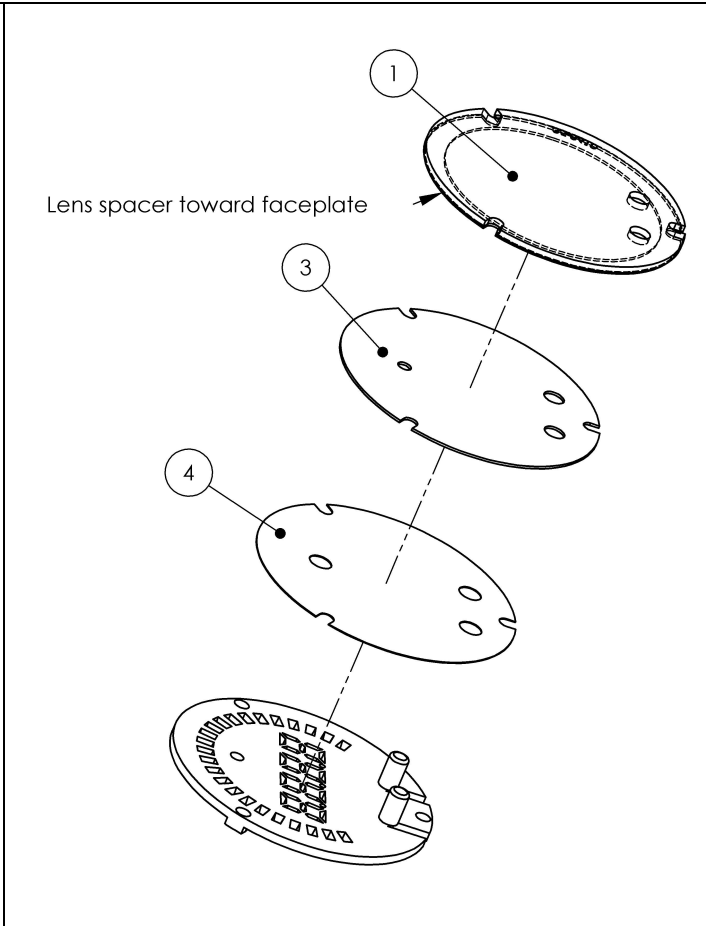

STEP 2 - Stack the diffuser (4), faceplate (3), and lens (1) in order, over the buttons, and on to the light guide

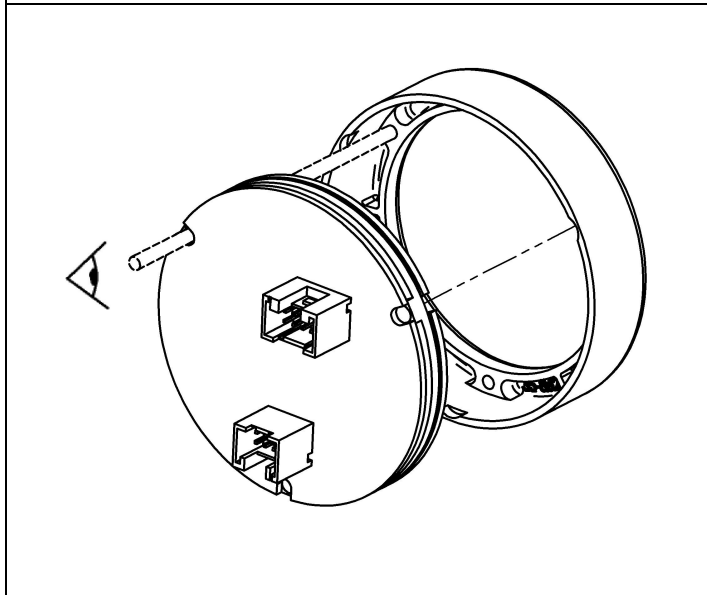

STEP 3 - Reassemble the PCB and display stack with the bezel, making sure screw holes are aligned through the entire assembly

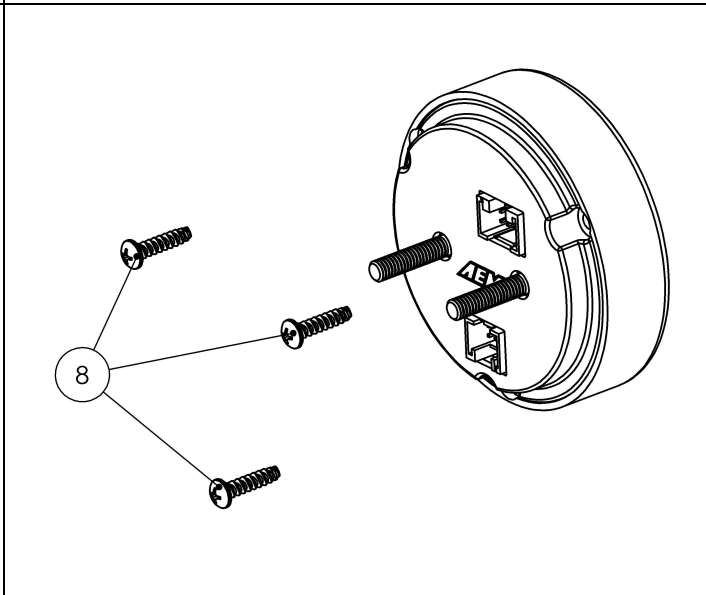

STEP 4 - Reassemble and tighten screws to 2 in-lb (previously assembled bezel) or 3 in-lb (new bezel). Do not over-tighten!

Gauge Installation

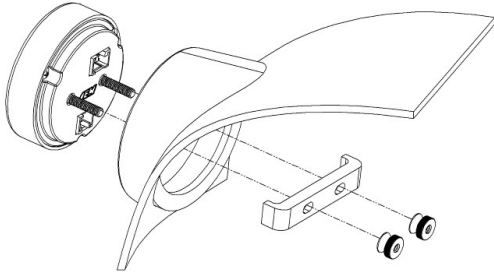

Installation using supplied bracket

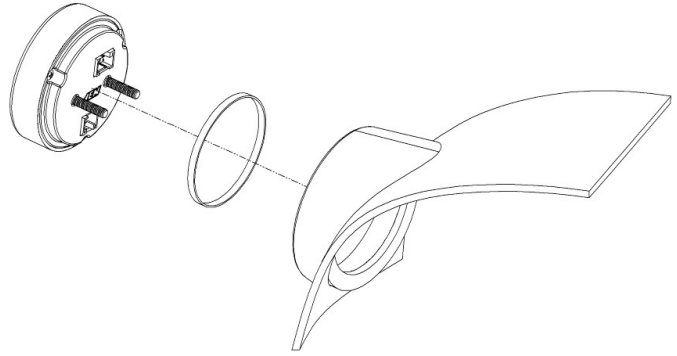

Installation without bracket, using rubber band

A 2-1/6" (52mm) hole is required to mount the X-Series gauge. A bracket and thumbscrews are provided to facilitate installation into a panel or gauge pod. In some cases, the gauge cup may be pushed into a mounting hole causing an interference fit strong enough to retain the gauge; the supplied rubber band may be fit to the gauge to create a tighter fit in mounting holes slightly larger than 52mm. It is, however, recommended that gauges be mounted securely using the supplied bracket to ensure they never become loose and cause a hazard during vehicle operation.

Note: The gauge is not water-proof and should not be installed in a location with exposure to water or snow. Damage caused by water ingress will not be covered under warranty.

0-5V Analog Output

WHITE WIRE = Analog Positive +
BROWN WIRE = Analog Negative -

0-5V Analog Output Scaling Formulas		
degF	=	(450.0 * Volts) - 225.0
degC	=	(250.0 * Volts) - 143.0

The 0-5V analog output is suitable for output to devices such as loggers or ECUs. This differential output requires special care to ensure proper operation. The WHITE signal wire should be connected to the positive of the analog input of the logging device or ECU; the BROWN wire must be connected to the negative of the analog input of the logging device or ECU. If the logging device or ECU does not have a differential analog input (both a dedicated positive and negative terminal for the analog input) then connect the BROWN wire to the shared signal ground. If the device does not have a dedicated signal ground then as a last course of action, connect it to the power ground of the logging device.

Important Note: If bench testing the analog output outside of a vehicle, a multimeter's positive lead may be connected to the WHITE wire however the BROWN wire must be connected to BOTH the multimeter's negative lead AND power ground going to the X-Series device. This connection is usually made by the circuitry inside an ECU or data logger.

0-5V Analog Output Scaling Table		
Volts	degF	degC
<0.50	SENSOR ERROR	
0.50	0	-18
0.75	113	45
1.00	225	107
1.25	338	170
1.50	450	232
1.75	563	295
2.00	675	357
2.25	788	420
2.50	900	482
2.75	1013	545
3.00	1125	607
3.25	1238	670
3.50	1350	732
3.75	1463	795
4.00	1575	857
4.25	1688	920
4.50	1800	982
>4.50	SENSOR ERROR	

AEMnet (CAN bus) Output

WHITE WIRE WITH BLACK STRIPE = AEMnet+ / CANH

GREEN WIRE WITH BLACK STRIPE = AEMnet- / CANL

The AEMnet output is suitable for output to AEM devices such as the AQ-1 data logger or Infinity ECU. The following CAN configuration and message definition information is provided below to facilitate interface with third-party devices.

Bus Termination

All AEMnet/CAN networks must be terminated to have an equivalent of approximately 60 Ohms of resistance. Generally, this means a 120 Ohm resistor connected in parallel to AEMnet+/AEMnet- (or CANH/CANL) at both physical ends of the bus run. The X-Series device does not have any internal termination and is intended to be connected to a pre-existing, properly terminated network. Please refer to the Bosch CAN2.0B specification for further detail.

bit rate	500	kb/sec
format	29	bit ID
transmit rate	20	hz
terminating resistor	none	
endianness	big / Motorola	
DLC	8	

Message ID	0x000A0305
------------	------------

Byte	Bit	Bitmask	Label	Data Type	Scaling	Offset	Range
0			Temperature	16 bit unsigned	1 degC/bit	0.0	0 to 65535 degC
1-7	-	-	-	-	-	-	-

FAQ / Troubleshooting

What are the minimum wiring connections needed to use the gauge?

Switched/fused 12V (RED) and power ground (BLACK) must be supplied to the 10 pin connector A and the sensor must be plugged into the harness. Any unused wires may be secured and fastened away for future use.

I installed my gauge correctly and the display just shows, "SEnS"

"SEnS" means that the gauge cannot read a valid signal from the sensor. Please ensure that the sensor is plugged in and that the wiring between the sensor and gauge is not damaged.

Can I extend the wires in my sensor harness?

Yes, but match the existing wire gauge use of proper crimping/soldering techniques is required.

For support, contact AEM Technical Support at 1-800-423-0046 or gentech@aemelectronics.com.

Specifications

Dimensions	diameter (bezel)	2.40 / 61	in / mm
	diameter (cup)	2-1/16 / 52	in / mm
	depth (incl. bezel)	0.825 / 21	in / mm
	depth (cup only)	0.200 / 5	in / mm
Sensor Installation	past finger tight	1.5 - 3.0	turns
	use liquid sealant		
Supply Voltage	min	7	VDC
	max	18	VDC
Supply Current (13.8V)	nominal	50.0	mA
Operating Temperature	min	-4 / -20	degF / degC
	max (16V Supply)	185 / 85	degF / degC
Analog Output	resolution	10	bit
	update rate	500	hz
CAN 2.0B Output	bit rate	500	kb/sec
	format	29	bit ID
	transmit rate	20	hz
	terminating resistor	none	
	endianness	big / Motorola	
	DLC	8	

12 Month Limited Warranty

Advanced Engine Management Inc. warrants to the consumer that all AEM High Performance products will be free from defects in material and workmanship for a period of twelve (12) months from date of the original purchase. Products that fail within this 12-month warranty period will be repaired or replaced at AEM's option, when determined by AEM that the product failed due to defects in material or workmanship. This warranty is limited to the repair or replacement of the AEM part. In no event shall this warranty exceed the original purchase price of the AEM part nor shall AEM be responsible for special, incidental or consequential damages or cost incurred due to the failure of this product. Warranty claims to AEM must be transportation prepaid and accompanied with dated proof of purchase. This warranty applies only to the original purchaser of product and is non-transferable. All implied warranties shall be limited in duration to the said 12-month warranty period. Improper use or installation, accident, abuse, unauthorized repairs or alterations voids this warranty. AEM disclaims any liability for consequential damages due to breach of any written or implied warranty on all products manufactured by AEM. Warranty returns will only be accepted by AEM when accompanied by a valid Return Merchandise Authorization (RMA) number. Product must be received by AEM within 30 days of the date the RMA is issued.

UEGO oxygen sensors are considered wear items and are not covered under warranty.

Please note that before AEM can issue an RMA for any electronic product, it is first necessary for the installer or end user to contact the EMS tech line at 1-800-423-0046 to discuss the problem. Most issues can be resolved over the phone. Under no circumstances should a system be returned or a RMA requested before the above process transpires.

AEM will not be responsible for electronic products that are installed incorrectly, installed in a non-approved application, misused, or tampered with.

Any AEM electronics product can be returned for repair if it is out of the warranty period. There is a minimum charge of \$50.00 for inspection and diagnosis of AEM electronic parts. Parts used in the repair of AEM electronic components will be extra. AEM will provide an estimate of repairs and receive written or electronic authorization before repairs are made to the product.